

Part No. 060828-10, Rev. E  
July 2024

# OmniSwitch 6570M Hardware Users Guide

Alcatel·Lucent   
Enterprise

[www.al-enterprise.com](http://www.al-enterprise.com)

---

This user guide documents OmniSwitch 6570M hardware, including chassis and associated components. The specifications described in this guide are subject to change without notice.

The Alcatel-Lucent name and logo are trademarks of Nokia used under license by ALE. To view other trademarks used by affiliated companies of ALE Holding, visit: [www.al-enterprise.com/en/legal/trademarks-copyright](http://www.al-enterprise.com/en/legal/trademarks-copyright). All other trademarks are the property of their respective owners. The information presented is subject to change without notice. Neither ALE Holding nor any of its affiliates assumes any responsibility for inaccuracies contained herein. © Copyright 2023 ALE International, ALE USA Inc. All rights reserved in all countries.



ALE USA Inc.  
2000 Corporate Center Dr.  
Thousand Oaks, CA 91320  
(818) 880-3500

**Service & Support Contact Information**

North America: 800-995-2696  
Latin America: 877-919-9526  
EMEA: +800 00200100 (Toll Free) or +1(650)385-2193  
Asia Pacific: +65 6240 8484  
Web: [myportal.al-enterprise.com](http://myportal.al-enterprise.com)  
Email: [ale.welcomecenter@al-enterprise.com](mailto:ale.welcomecenter@al-enterprise.com)

# Contents

	<b>About This Guide</b> .....	vii
	Supported Platforms .....	vii
	Who Should Read this Manual? .....	vii
	When Should I Read this Manual? .....	vii
	What is in this Manual? .....	vii
	What is Not in this Manual? .....	viii
	How is the Information Organized? .....	viii
	Documentation Roadmap .....	viii
	Related Documentation .....	x
	Technical Support .....	xi
<b>Chapter 1</b>	<b>OmniSwitch 6570M</b> .....	1-1
	OmniSwitch 6570M Availability Features .....	1-2
	Power Supply Redundancy .....	1-2
	Hot-Swapping .....	1-2
	Hardware Monitoring .....	1-2
<b>Chapter 2</b>	<b>Getting Started</b> .....	2-1
	Installing the Hardware .....	2-1
	Items Required .....	2-1
	Site Preparation .....	2-1
	Environmental Requirements .....	2-1
	Electrical Requirements .....	2-1
	Electrical Surge Warning .....	2-2
	Unpacking and Installing the Switch .....	2-2
	Items Included .....	2-3
	Weight Considerations .....	2-3
	Connections and Cabling .....	2-4
	Network Cable Installation Warning .....	2-4
	Serial Connection to the Console Port .....	2-4
	Serial Connection Default Settings .....	2-4
	Ethernet Management Port (EMP) Cable Requirements .....	2-4
	Booting the Switch .....	2-5
	Component LEDs .....	2-5
	Your First Login Session .....	2-6
	Logging In to the Switch .....	2-6
	Unlocking Session Types .....	2-7
	Changing the Login Password .....	2-7

Setting the System Time Zone .....	2-8
Setting the Date and Time .....	2-8
Setting Optional Parameters .....	2-8
Specifying an Administrative Contact .....	2-8
Specifying a System Name .....	2-8
Specifying the Switch's Location .....	2-8
Viewing Your Changes .....	2-9
Saving Your Changes .....	2-9
<b>Chapter 3 Chassis and Power Supplies .....</b>	<b>3-1</b>
Chassis Details .....	3-2
OS6570M-12 .....	3-2
OS6570M-12 Front Panel .....	3-2
OS6570M-12 Rear Panel .....	3-3
OS6570M-12 Chassis Specifications .....	3-3
OS6570M-12D .....	3-4
OS6570M-12D Front Panel .....	3-4
OS6570M-12D Rear Panel .....	3-5
OS6570M-12D Chassis Specifications .....	3-5
OS6570M-U28 .....	3-6
OS6570M-U28 Front Panel .....	3-6
OS6570M-U28 Rear Panel .....	3-6
OS6570M-U28 Chassis Specifications .....	3-7
Chassis Status LEDs .....	3-8
Mounting the Switch .....	3-9
General Mounting Recommendations .....	3-9
Airflow / Clearance Recommendations .....	3-9
Rack Mounting Steps (Full-width Chassis) .....	3-10
Rack Mounting Steps (One Half-width Chassis - OS6570M-RM-19-L Kit) .....	3-11
Rack Mounting Steps (Two Half-width Chassis - OS6570M-DUO-MNT Kit) .....	3-13
Power Supplies .....	3-16
Internal Power Supplies .....	3-16
60W AC Power Supply .....	3-17
30W DC Power Supply .....	3-18
LED States .....	3-18
150W AC Power Supply .....	3-19
LED States .....	3-19
150W DC Power Supply .....	3-20
LED States .....	3-20
DC Power Supply Connections .....	3-21
Connecting a DC Cable Harness to the Chassis Power Supply .....	3-21
Connecting a DC Cable Harness to the DC Power Source .....	3-21
Installing Power Supplies .....	3-22
Hot-Swapping / Removing Power Supplies .....	3-23
Installing Power Supply Trays .....	3-25
Grounding the Chassis .....	3-26
Monitoring Chassis Components .....	3-26
Viewing Chassis Slot Information .....	3-26
Monitoring Chassis Temperature .....	3-26

Temperature Errors .....	3-26
Dying Gasp .....	3-27
Scenarios .....	3-27
SNMP Trap .....	3-27
Syslog Message .....	3-28
Link OAM PDU .....	3-28
Link OAM PDU Priority .....	3-28

<b>Appendix A</b>	<b>Regulatory Compliance and Safety Information .....</b>	<b>A-1</b>
	Declaration of Conformity: CE Mark .....	A-1
	Waste Electrical and Electronic Equipment (WEEE) Statement .....	A-1
	China RoHS: Hazardous Substance Table .....	A-2
	Taiwan RoHS: Hazardous Substance Table .....	A-3
	California Proposition 65 Warning .....	A-3
	Standards Compliance .....	A-4
	FCC Class A, Part 15 .....	A-7
	Canada Class A Statement .....	A-7
	JATE .....	A-7
	CISPR22 Class A warning .....	A-7
	Korea Emissions Statement .....	A-8
	VCCI .....	A-8
	Class A Warning for Taiwan and Other Chinese Markets .....	A-8
	Class 1M Laser Warning .....	A-8
	Network Cable Installation Warning .....	A-8
	Translated Safety Warnings .....	A-9
	Blank Panels Warning .....	A-9
	Electrical Storm Warning .....	A-9
	Installation Warning .....	A-9
	Invisible Laser Radiation Warning .....	A-10
	Operating Voltage Warning .....	A-10
	Power Disconnection Warning .....	A-10
	Proper Earthing Requirement Warning .....	A-11
	DC Power Supply Connection Warning .....	A-11
	Read Important Safety Information Warning .....	A-12
	Restricted Access Location Warning .....	A-12
	Wrist Strap Warning .....	A-12
	Instrucciones de seguridad en español .....	A-13
	Advertencia sobre el levantamiento del chasis .....	A-13
	Advertencia de las tapaderas en blanco .....	A-13
	Advertencia en caso de tormenta eléctrica .....	A-13
	Advertencia de instalación .....	A-13
	Advertencia de radiación láser invisible .....	A-13
	Advertencia de la batería de litio .....	A-13
	Advertencia sobre la tensión de operación .....	A-13
	Advertencia sobre la desconexión de la fuente .....	A-13
	Advertencia sobre una apropiada conexión a tierra .....	A-14
	Leer “información importante de seguridad” .....	A-14

Advertencia de acceso restringido ..... A-14  
Advertencia de pulsera antiestática ..... A-14  
Clase de seguridad ..... A-14  
Advertencia de fuentes de poder ..... A-14

# About This Guide

This *OmniSwitch 6570M Hardware Users Guide* describes OmniSwitch 6570M switch components and basic switch hardware procedures.

## Supported Platforms

The information in this guide applies only to OmniSwitch 6570M switches.

## Who Should Read this Manual?

The audience for this users guide is network administrators and IT support personnel who need to configure, maintain, and monitor switches and routers in a live network. However, anyone wishing to gain knowledge of the hardware will benefit from the material in this guide.

## When Should I Read this Manual?

Read this guide as soon as you are ready to familiarize yourself with your switch hardware components.

You should already be familiar with the very basics of the switch hardware, such as module LEDs and component installation procedures. This manual will help you understand your switch hardware in greater depth.

## What is in this Manual?

This users guide includes the following hardware-related information:

- Descriptions of “Availability” features.
- Technical specifications for the chassis, power supplies and modules.
- Power supply requirements.
- The dynamics of chassis airflow, including detailed illustrations of proper and improper airflow configurations.
- Hot-swapping power supplies.
- Installation and removal procedures for power supplies and modules.
- Detailed illustrations and LED descriptions for chassis, network and power supply operability.

- 
- Hardware-related Command Line Interface (CLI) commands.

## What is Not in this Manual?

The descriptive and procedural information in this manual focuses on switch hardware. It includes information on some CLI commands that pertain directly to hardware configuration, but it is not intended as a software users guide. There are several OmniSwitch users guides that focus on switch software configuration. Consult those guides for detailed information and examples for configuring your switch software to operate in a live network environment. See [“Documentation Roadmap” on page -viii](#) and [“Related Documentation” on page -ix](#) for further information on software configuration guides available for your switch.

## How is the Information Organized?

Each chapter in this guide focuses on a specific hardware component or a set of hardware components. All descriptive, technical specification, and procedural information for a hardware component can be found in the chapter dedicated to that component.

## Documentation Roadmap

The OmniSwitch user documentation suite was designed to supply you with information at several critical junctures of the configuration process. The following section outlines a roadmap of the manuals that will help you at each stage of the configuration process. Under each stage, we point you to the manual or manuals that will be most helpful to you.

### Stage 1: Using the Switch for the First Time

**Pertinent Documentation:** *Getting Started Information*  
*Release Notes*

A “Getting Started” chapter is included in the *OmniSwitch 6570M Hardware Users Guide*. This chapter provides all the information you need to get your switch up and running the first time. It also includes succinct overview information on fundamental aspects of the switch.

At this time you should also familiarize yourself with the Release Notes that accompanied your switch. This document includes important information on feature limitations that are not included in other user guides.

### Stage 2: Gaining Familiarity with Basic Switch Functions

**Pertinent Documentation:** *Hardware Users Guide*  
*OmniSwitch AOS Release 8 Switch Management Guide*

Once you have your switch up and running, you will want to begin investigating basic aspects of its hardware and software. Information about switch hardware is provided in the *OmniSwitch 6570M Hardware Guide*. This guide provides specifications, illustrations, and descriptions of all hardware components. It also includes steps for common procedures, such as removing and installing switch components.



---

This guide is the primary users guide for the basic software features on a single switch. This guide contains information on the switch directory structure, basic file and directory utilities, switch access security, SNMP, and web-based management. It is recommended that you read this guide before connecting your switch to the network.

### Stage 3: Integrating the Switch Into a Network

**Pertinent Documentation:** *OmniSwitch AOS Release 8 Network Configuration Guide*

When you are ready to connect your switch to the network, you will need to learn how the OmniSwitch implements fundamental software features, such as 802.1Q, VLANs, Spanning Tree, and network routing protocols. The *Network Configuration Guide* guide contains overview information, procedures, and examples on how standard networking technologies are configured on the OmniSwitch.

#### Anytime

The *OmniSwitch AOS Release 8 CLI Reference Guide* contains comprehensive information on all CLI commands supported by the switch. This guide includes syntax, default, usage, example, related CLI command, and CLI-to-MIB variable mapping information for all CLI commands supported by the switch. This guide can be consulted anytime during the configuration process to find detailed and specific information on each CLI command.

## Related Documentation

The following are the titles and descriptions of all the OmniSwitch 6570M user manuals:

- *OmniSwitch 6570M Hardware Users Guide*  
Complete technical specifications and procedures for all OmniSwitch 6570M chassis, power supplies, and Network Interface (NI) modules.
- *OmniSwitch AOS Release 8 CLI Reference Guide*  
Complete reference to all CLI commands supported on the OmniSwitch. Includes syntax definitions, default values, examples, usage guidelines and CLI-to-MIB variable mappings.
- *OmniSwitch AOS Release 8 Switch Management Guide*  
Includes procedures for readying an individual switch for integration into a network. Topics include the software directory architecture, image rollback protections, authenticated switch access, managing switch files, system configuration, using SNMP, and using web management software (WebView).
- *OmniSwitch AOS Release 8 Network Configuration Guide*  
Includes network configuration procedures and descriptive information on all the major software features and protocols included in the base software package. Chapters cover Layer 2 information (Ethernet and VLAN configuration), Layer 3 information (routing protocols, such as RIP and IPX), security options (authenticated VLANs), Quality of Service (QoS), link aggregation, and server load balancing.
- Technical Tips, Field Notices  
Includes information published by Alcatel-Lucent's Customer Support group.
- *Release Notes*

---

Includes critical Open Problem Reports, feature exceptions, and other important information on the features supported in the current release and any limitations to their support.

## Technical Support

A service agreement brings your company the assurance of 7x24 no-excuses technical support. You'll also receive regular software updates to maintain and maximize your product's features and functionality and on-site hardware replacement through our global network of highly qualified service delivery partners.

With 24-hour access to the Service and Support web page, you'll be able to view and update any case (open or closed) that you have reported to technical support, open a new case or access helpful release notes, technical bulletins, and manuals.

Access additional information can be found below:

Web: [myportal.al-enterprise.com](http://myportal.al-enterprise.com)

Phone: 1-800-995-2696

Email: [ale.welcomecenter@al-enterprise.com](mailto:ale.welcomecenter@al-enterprise.com)

# 1 OmniSwitch 6570M

Refer to the information below for OmniSwitch 6570M models and components.

Model Number	Description
OS6570M-12	Fixed-configuration chassis with: <ul style="list-style-type: none"><li>• 8 - RJ45 10/100/1000Base-T ports</li><li>• 2 - 100/1000Base-X SFP ports</li><li>• 2 - Uplink/Stacking SFP+ Ports (1G/10G)</li><li>• 1 - Internal AC Power Supply</li><li>• 1 - External Power Connector</li></ul> See <a href="#">“OS6570M-12” on page 3-2</a>
OS6570M-12D	Fixed-configuration chassis with: <ul style="list-style-type: none"><li>• 8 - RJ45 10/100/1000Base-T ports</li><li>• 2 - 100/1000Base-X SFP ports</li><li>• 2 - Uplink/Stacking SFP+ Ports (1G/10G)</li><li>• 1 - Internal DC Power Supply</li><li>• 1 - External Power Connector</li></ul> See <a href="#">“OS6570M-12D” on page 3-4</a>
OS6570M-U28	Fixed-configuration chassis with: <ul style="list-style-type: none"><li>• 20 - 100/1000Base-X SFP ports</li><li>• 4 - SFP/RJ45 1G combo ports</li><li>• 6 - Uplink/Stacking SFP+ Ports (1G/10G)</li><li>• 2 - Power Supply Bays</li></ul> See <a href="#">“OS6570M-U28” on page 3-6</a>

## OmniSwitch 6570M Availability Features

The switch provides a broad variety of availability features. Availability features are hardware and software-based safeguards that help prevent the loss of data flow in the unlikely event of a subsystem failure. In addition, some availability features allow users to maintain or replace hardware components without powering off the switch or interrupting switch operations. Combined, these features provide added resiliency and help ensure that the switch is consistently available for day-to-day network operations.

Hardware-related availability features include:

- [Power Supply Redundancy](#)
- [Hot-Swapping](#)
- [Hardware Monitoring](#)

## Power Supply Redundancy

Multiple power supplies can be used for power supply redundancy or load sharing on supported models. For information on power supplies, refer to [Chapter 3, “Chassis and Power Supplies.”](#)

## Hot-Swapping

Hot-swapping refers to the action of adding, removing, or replacing certain hardware components without powering off your switch and disrupting other components in the chassis. This feature greatly facilitates hardware upgrades and maintenance and also allows you to easily replace components in the unlikely event of hardware failure.

## Hardware Monitoring

### Automatic Monitoring

Automatic monitoring refers to the switch’s built-in sensors that automatically monitor operations. If an error is detected (e.g., over-threshold temperature), the switch immediately sends a trap to the user. The trap is displayed on the console in the form of a text error message.

### LEDs

LEDs, which provide visual status information, are provided on the front and rear panels. LEDs are used to indicate conditions, such as hardware and software status, link integrity, data flow, etc. For detailed LED descriptions, refer to the corresponding hardware component section in the next chapter.

### User-Driven Monitoring

User-driven hardware monitoring refers to CLI commands that are entered by the user in order to access the current status of hardware components. The user enters “show” commands that output information to the console. The show commands for all the features are described in detail in the *OmniSwitch CLI Reference Guide*.

# 2 Getting Started

## Installing the Hardware

---

**Note.** For information on configuring a Virtual Chassis (VC), refer to the *OmniSwitch AOS Release 8 Switch Management Guide*.

---

### Items Required

- Grounding wrist strap
- Phillips screwdriver
- Flat-blade screwdriver

### Site Preparation

#### Environmental Requirements

The switches have the following environmental and airflow requirements:

- The installation site must maintain a supported temperature and humidity range as given in the specifications table for the chassis.
- Be sure to allow adequate room for proper air ventilation around the chassis. Refer to [“Mounting the Switch” on page 3-9](#) for minimum clearance requirements.

#### Electrical Requirements

---

**Note.** Switches must be installed by a professional installer. It is the responsibility of the installer to ensure that proper grounding is available and that the installation meets applicable local and national electrical codes.

---

The switches have the following general electrical requirements:

- Each switch requires one grounded electrical outlet for each power supply installed in the chassis.
- For switches using AC power connections, each supplied AC power cord is 2 meters (approx. 6.5 feet). Do not use extension cords.
- ALE provided power cords are UL recognized to IEC 62368-1 exceeding the maximum amperage requirement for the power source. If using a non-ALE provided power cord the installer shall confirm it meets the minimum electrical requirements of the power source.

---

**Redundant AC Power.** It is recommended that each AC outlet resides on a separate circuit. With redundant AC, if a single circuit fails, the switch's remaining power supplies (on separate circuits) can remain operational.

---

## Electrical Surge Warning

In order to help protect equipment against electrical surges please take note of the following recommendations and guidelines:

- 1** Earth grounding of all devices is fundamental to ensure long term reliability.
  - All electrical equipment must be installed by a qualified, licensed electrician.
  - Every power supply that is connected to building power should be earth grounded.
  - Earth grounding for the power cable, should be verified to be 0.01 ohm or less.
  - Each switch should be grounded to same earth ground as the power supply.
  - Each powered device, such as an AP or camera, should be connected to earth ground.
  - Each surge suppression device should be connected to earth ground.
  
- 2** Shielded cables (STP) offer some minimal level of additional protection over unshielded Ethernet cables (UTP) but the use of a surge protector is still recommended.
  - It is suggested to use STP Cat5e or better for 1Gbps Ethernet switches for any outdoor application or applications where Ethernet cables come in close proximity to alternating current conductors.
  - Always install cables according to manufacturer requirements.
  
- 3** For any connections where integrity of the cabling within a building ground is questionable (i.e outdoor connections), copper Ethernet ports must be connected with an appropriate surge protection device, inline, between the PSE and PD per the manufacturer's recommendations for connection and grounding.
  
- 4** Caution should be taken for any cable connected to any outdoor device, not only on the device grounding, but to ensure that any outdoor device cables that could carry surge currents, do not pass those surge currents to upstream Ethernet switches.
  
- 5** Caution - Category 5e, Category 6, and Category 6a cables can store large amounts of static electricity due to the dielectric properties of their construction materials in addition, this build up of electricity could lead to a Cable Discharge Event (CDE). A CDE can occur due to the differential in charges on the cable and the equipment it's being connected to. It is recommended that installers momentarily ground all copper Ethernet cables (especially in new cable runs) to a suitable and safe earth ground before connecting them to the port.

---

**Note.** Failure to follow the above recommendations could result in voiding the warranty of the affected ALE product.

---

## Unpacking and Installing the Switch

To protect your switch components from damage, read all unpacking recommendations and instructions carefully before beginning.

Unpack your chassis as close as possible to the location where it will be installed.

### Items Included

Your OmniSwitch may include the following items:

- OmniSwitch chassis with power supplies, per order
- Transceivers, per order
- Blank cover panel
- Rack mount brackets
- Country-specific power cord(s)
- Rubber table-mounting feet
- Attachment screws
- Assorted instructional cards, anti-static bags and additional packaging

### Weight Considerations

Weights vary depending on model type. Please refer to the chassis specifications table.

## Connections and Cabling

Once your switch is properly installed, you should connect all network and management cables required for your network applications. Connections may include:

- Console connector
- Cables to NIs or transceivers

### Network Cable Installation Warning

Never install exposed network cables outdoors. Install network cables per manufacturer requirements.

### Serial Connection to the Console Port

The console port provides a serial connection to the switch is required when logging into the switch for the first time. By default, this connector provides a DCE console connection.

## Serial Connection Default Settings

<b>baud rate</b>	9600
<b>parity</b>	none
<b>data bits (word size)</b>	8
<b>stop bits</b>	1

For information on modifying these settings, refer to the *Switch Management Guide*.

## Ethernet Management Port (EMP) Cable Requirements

There is an EMP port provided on the chassis for out-of-band management. There are specific cable type requirements (i.e., straight-through or crossover) based on the device to which the EMP is connecting. Refer to the information below:

<b>EMP to a Switch</b>	Straight-through
<b>EMP to a Computer or Workstation</b>	Crossover

For information on manually configuring Ethernet ports, refer to the *OmniSwitch AOS Release 8 Network Configuration Guide*.

# Booting the Switch

Now that you have installed the switch components and connected network and management cables, you can boot the switch. To boot the switch, plug all power supply cords into easily-accessible, properly grounded power outlets. (Do not use extension cords.) The switch will power on and boot automatically.

---

**Note.** If you have more than one power supply installed, be sure to plug in each power supply in rapid succession, (i.e., within a few seconds of each other). This ensures that there will be adequate power for all components throughout the boot process.

---

## Component LEDs

During the boot process, component LEDs will flash and change color, indicating different stages of the boot. For complete information on LED states, refer to [“Chassis Status LEDs” on page 3-8](#).

Once the switch has completely booted and you have accessed your computer’s terminal emulation software via the console port, you are ready to log in to the switch’s Command Line Interface (CLI) and configure basic information. Continue to [“Your First Login Session” on page 2-4](#).

# Your First Login Session

In order to complete the setup process for the switch, you must complete the following steps during your first login session:



- Log in to the switch
- Unlock session types
- Change the login password
- Set the date and time
- Set optional system information
- Save your changes

---

**Important.** You must be connected to the switch via the console port before initiating your first login session.

---

## Logging In to the Switch

When you first log in to the switch, you will be prompted for a login name and password. Use the switch's default settings:

- Login: **admin**
- Password: **switch**

The default welcome banner, which includes information such as the current software version and system date, is displayed followed by the CLI command prompt:

```
Welcome to the Alcatel-Lucent Enterprise OmniSwitch 8.5.R01, February 15, 2018.
```

```
Copyright (c) ALE-USA Inc., 2014-2021. All Rights Reserved.
```

```
OmniSwitch(tm) is a trademark of Alcatel-Lucent, registered in the United States  
Patent and Trademark Office.
```

```
->
```

---

**Note.** A user account includes a login name, password, and user privileges. Privileges determine whether the user has read or write access to the switch and which commands the user is authorized to execute. For detailed information on setting up and modifying user accounts, refer to the *Switch Management Guide*.

---

## Unlocking Session Types

Security is a key feature on an OmniSwitch switch. As described on [page 2-4](#), when you access the switch for the first time, you must use a *direct console port connection*. All other session types (Telnet, FTP, WebView, and SNMP) are locked out until they are manually unlocked by the user.

The CLI command used to unlock session types is **aaa authentication**.

---

**Note.** When you unlock session types, you are granting switch access to non-local sessions (e.g., Telnet). As a result, users who know the correct user login and password will have remote access to the switch. For more information on switch security, refer to the *Switch Management Guide*.

---

## Unlocking All Session Types

To unlock all session types, enter the following command syntax at the CLI prompt:

```
-> aaa authentication default local
```

## Unlocking Specified Session Types

You can also unlock session types on a one-by-one basis. For example, to unlock Telnet sessions only, enter the following command:

```
-> aaa authentication telnet local
```

To unlock WebView (HTTP) sessions only, enter the following command:

```
-> aaa authentication http local
```

You cannot specify more than one session type in a single command line. However, you can still unlock multiple session types by using the **aaa authentication** command in succession. For example:

```
-> aaa authentication http local
-> aaa authentication telnet local
-> aaa authentication ftp local
```

Refer to the *OmniSwitch CLI Reference Guide* for complete **aaa authentication** command syntax options.

## Changing the Login Password

Change the login password for **admin** user sessions by following the steps below:

- 1 Be sure that you have logged into the switch as user type **admin** (see [“Logging In to the Switch” on page 2-5](#)).
- 2 Enter the keyword **password** and press **Enter**.
- 3 Enter your new password at the prompt.

---

**Note.** Be sure to remember or securely record all new passwords; overriding configured passwords on an OmniSwitch is restricted.

---

- 4 You will be prompted to re-enter the password. Enter the password a second time.

New password settings are automatically saved in real time to the local user database; the user is not required to enter an additional command in order to save the password information. Also note that new password information is retained following a reboot. All subsequent login sessions, including those through the console port, will require the new password to access the switch.

For detailed information on managing login information, including user names and passwords, refer to the *Switch Management Guide*.

## Setting the System Time Zone

The switch's default time zone is UTC. If you require a time zone that is specific to your region, or if you need to enable Daylight Savings Time (DST) on the switch, you can configure these settings via the **system timezone** and **system daylight-savings-time** commands.

For detailed information on configuring a time zone for the switch, refer to the *Switch Management Guide*.

## Setting the Date and Time

Set the current time for the switch by entering **system time**, followed by the current time in *hh:mm:ss*.

To set the current date for the switch, enter **system date**, followed by the current date in *mm/dd/yyyy*.

## Setting Optional Parameters

### Specifying an Administrative Contact

An administrative contact is the person or department in charge of the switch. If a contact is specified, users can easily find the appropriate network administrator if they have questions or comments about the switch. To specify an administrative contact, use the **system contact** command.

### Specifying a System Name

The system name is a simple, user-defined text description for the switch. To specify a system name, use the **system name** command.

### Specifying the Switch's Location

It is recommended that you use a physical labeling system for locating and identifying your switch(es). Examples include placing a sticker or placard with a unique identifier (e.g., the switch's default IP address) on each chassis. However, if no labeling system has been implemented or if you need to determine a switch's location from a remote site, entering a system location can be very useful. To specify a system location, use the **system location** command.

## Viewing Your Changes

To view your current changes, enter **show system** at the CLI prompt.

## Saving Your Changes

Once you have configured this basic switch information, save your changes by entering **write memory** at the CLI command prompt.



# 3 Chassis and Power Supplies

This chapter includes detailed information on the chassis types. Topics include:

- Chassis details and technical specifications:
  - OS6570M-12, [page 3-2](#).
  - OS6570M-12D, [page 3-4](#).
  - OS6570M-U28, [page 3-6](#).
- Mounting the Switch, [page 3-9](#).
- Power supplies, [page 3-16](#).
  - Internal Power Supplies, [page 3-16](#).
  - OS6570M-12 AC Power Supply, [page 3-17](#).
  - OS6570M-12D DC Power Supply, [page 3-18](#).
  - OS6570M-U28 AC Power Supply, [page 3-17](#).
  - OS6570M-U28 DC Power Supply, [page 3-20](#).
- Temperature management, [page 3-26](#).
- Monitoring the chassis components via the Command Line Interface (CLI), [page 3-26](#)

# Chassis Details

## OS6570M-12

### OS6570M-12 Front Panel

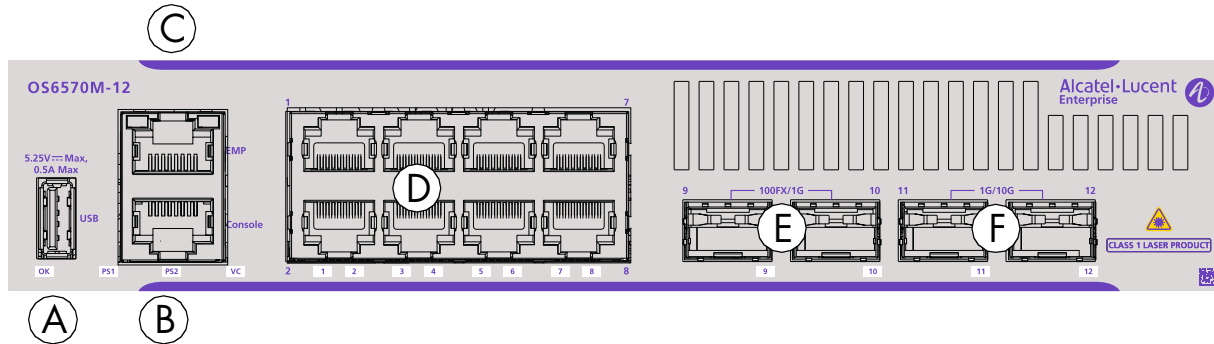

Item	Description
A	USB port
B	Console port
C	EMP port (Out-of-band Management Port)
D	(1-8) 10/100/1000Base-T ports
E	(9-10) 100/1000Base-X SFP ports
F	(11-12) Uplink/Stacking SFP+ Ports (1G/10G)
LEDs	See “Chassis Status LEDs” on page 3-8

**CLASS 1 M LASER CAUTION. CAUTION - CLASS 1 M LASER RADIATION WHEN OPEN. DO NOT VIEW DIRECTLY WITH OPTICAL INSTRUMENTS**

## OS6570M-12 Rear Panel

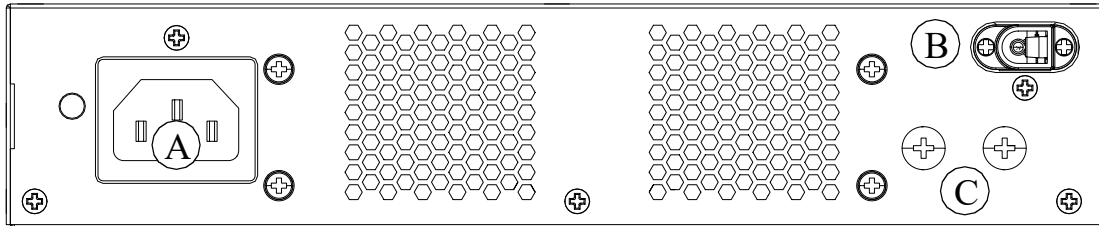

Item	Description
A	AC Power Connector
B	Power Connector
C	Grounding Lug

## OS6570M-12 Chassis Specifications

Chassis Height	4.4 cm (1.73 in.)
Chassis Width	21.72 cm (8.55 in.)
Chassis Depth	28.07 cm (11.05 in.)
Chassis Weight	1.7 kg (3.7 lb)
Ambient Operating Temperature (T <sub>mra</sub> )	0°C to 50°C (32°F to 122°F)
Warning Threshold ( <i>Thresh</i> ) (internal)	85°C (185°F)
Danger Threshold (internal)	88°C (190°F)
Storage Temperature	-20°C to 60°C (-4°F to 140°F)
Operating Humidity	5% to 95% non-condensing
Storage Humidity	5% to 95% non-condensing
Power Consumption (idle)	23 W
Refer to <a href="#">“Monitoring Chassis Temperature”</a> on page 3-26 for an explanation of the Warning and Danger Thresholds.	

**\*Note On Chassis Versus Ambient Temperatures.** Internal temperature refers to the sensor reading of the internal switch temperature. Ambient temperature (T<sub>mra</sub>) refers to the approximate room temperature. The ambient temperature will typically be lower than the internal temperature.

# OS6570M-12D

## OS6570M-12D Front Panel

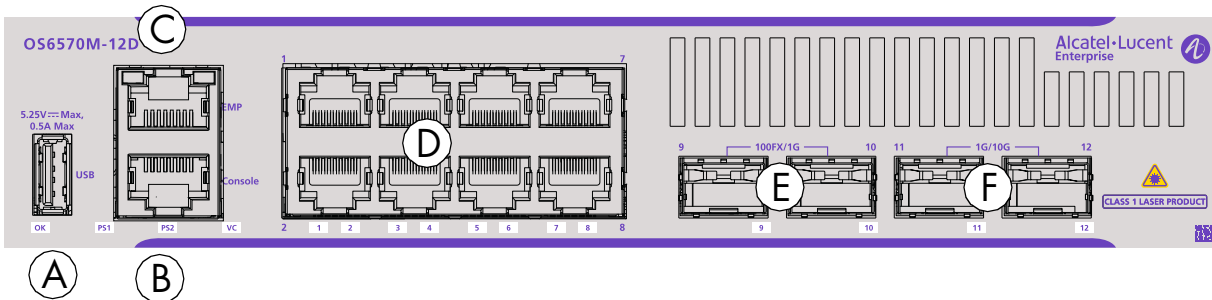

Item	Description
A	USB port
B	Console port
C	EMP port (Out-of-band Management Port)
D	(1-8) 10/100/1000Base-T ports
E	(9-10) 100/1000Base-X SFP ports
F	(11-12) Uplink/Stacking SFP+ Ports (1G/10G)
LEDs	See “Chassis Status LEDs” on page 3-8

**CLASS 1 M LASER CAUTION.** CAUTION - CLASS 1 M LASER RADIATION WHEN OPEN.  
DO NOT VIEW DIRECTLY WITH OPTICAL INSTRUMENTS



## OS6570M-12D Rear Panel

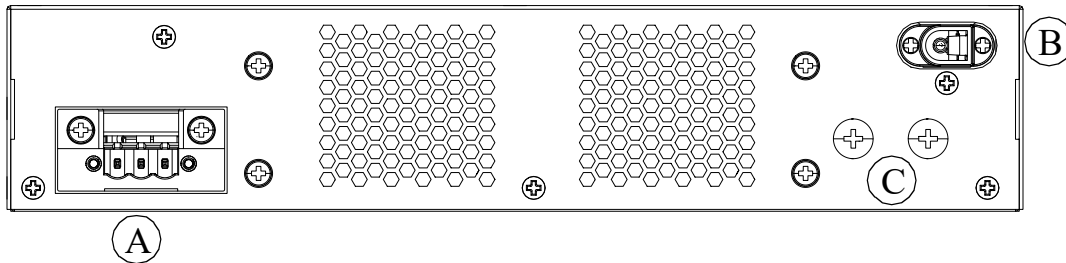

Item	Description
A	DC Power Connector
B	Power Connector
C	Grounding Lug

## OS6570M-12D Chassis Specifications

Chassis Height	4.4 cm (1.73 in.)
Chassis Width	21.72 cm (8.55 in.)
Chassis Depth	28.07 cm (11.05 in.)
Chassis Weight	1.7 kg (3.7 lb)
Ambient Operating Temperature (T <sub>mra</sub> )	0°C to 50°C (32°F to 122°F)
Storage Temperature	-40°C to 85°C (-40°F to 185°F)
Warning Threshold ( <i>Thresh</i> ) (internal)	85°C (185°F)
Danger Threshold (internal)	88°C (190°F)
Operating Humidity	5% to 95% non-condensing
Storage Humidity	5% to 95% non-condensing
Power Consumption (idle)	24 W

Refer to [“Monitoring Chassis Temperature” on page 3-26](#) for an explanation of the Warning and Danger Thresholds.

When connecting in dual-redundant power supply configuration, both power supplies must have identical output wattage and identical nominal output voltage. Use of dissimilar power supplies could result in unexpected behavior and is not supported.

**\*Note On Chassis Versus Ambient Temperatures.** Internal temperature refers to the sensor reading of the internal switch temperature. Ambient temperature (T<sub>mra</sub>) refers to the approximate room temperature. The ambient temperature will typically be lower than the internal temperature.

## OS6570M-U28

### OS6570M-U28 Front Panel

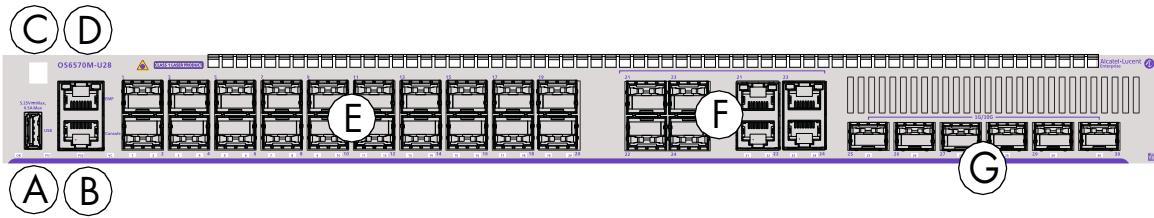

Item	Description
A	USB port
B	Console port
C	Virtual Chassis ID LED
D	EMP port (Out-of-band Management Port)
E	(1-20) 100/1000Base-X SFP ports
F	(21-24) SFP/RJ45 1G combo ports
G	(25-30) Uplink/Stacking SFP+ Ports (1G/10G)
LEDs	See “Chassis Status LEDs” on page 3-8

**CLASS 1 M LASER CAUTION.** CAUTION - CLASS 1 M LASER RADIATION WHEN OPEN.  
DO NOT VIEW DIRECTLY WITH OPTICAL INSTRUMENTS

### OS6570M-U28 Rear Panel

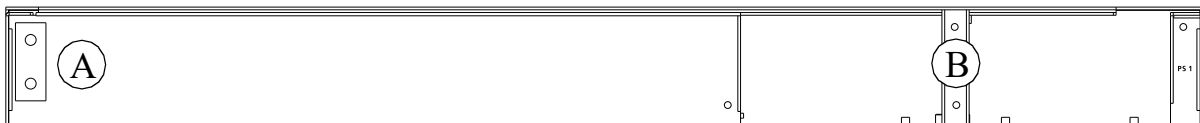

Item	Description
A	Grounding Lug
B	Power Supply Bays

## OS6570M-U28 Chassis Specifications

---

Chassis Height	4.4 cm (1.73 in)
Chassis Width	44 cm (17.32 in)
Chassis Depth	35 cm (13.78)
Chassis Weight (without power supplies)	4.08 kg (8.99 lb)
Power Consumption (idle)	71 W
Ambient Operating Temperature (T <sub>mra</sub> )	0°C to 50°C (32°F to 122°F)
Warning Threshold ( <i>Thresh</i> ) (internal)	69°C (156°F)
Danger Threshold (internal)	74°C (165°F)
Storage Temperature	-40°C to 85°C (-40°F to 185°F)
Operating Humidity	5% to 95% non-condensing
Storage Humidity	5% to 95% non-condensing

---

Refer to [“Monitoring Chassis Temperature”](#) on page 3-26 for an explanation of the Warning and Danger Thresholds.

---

---

**\*Note On Chassis Versus Ambient Temperatures.** Internal temperature refers to the sensor reading of the internal switch temperature. Ambient temperature (T<sub>mra</sub>) refers to the approximate room temperature. The ambient temperature will typically be lower than the internal temperature.

---

## Chassis Status LEDs

The chassis provides a series of status LEDs located on the front panel. These LEDs offer basic status information for hardware operation and port link and activity status.

LED	State	Description
OK	Solid Green	System Diagnostics and AOS bootup OK.
	Blinking Green	System Diagnostics and AOS in progress. (i.e., performing diagnostics or booting)
	Solid Amber	System Diagnostics and/or AOS bootup failed.
VC	Solid Green	This unit is the master unit.
	Solid Amber	This unit is a slave unit.
	Blinking Amber (12-port models only)	Identifies unit number by the number of blinks.
	Off	This unit is in shutdown mode or is not part of a VC.
PS1/PS2 (U28)	Solid Green	Power supply functioning normally.
	Solid Amber	Power supply not functioning normally.
	Off	Power supply not present.
PS1/PS2 (12-port models)	Solid Green	Power supply functioning normally.
	Off	Power supply not present.
10/100/1000 Port LEDs	Solid Green	Valid port link.
	Blinking Green	Valid port link with activity.
SFP 100/1000Base-X Port LEDs	Solid Green	Valid port link.
	Blinking Green	Valid port link with activity.
SFP+ Port LEDs	Solid Green	Valid 1G/10G port link.
	Blinking Green	Valid 1G/10G port link with activity.

# Mounting the Switch

## General Mounting Recommendations

**Elevated Operating Ambient Temperature.** If installed in a closed or multi-rack assembly, the operating ambient temperature of the environment may be greater than the room's ambient temperature. Therefore, consideration should be given to the maximum rated ambient temperature (T<sub>mra</sub>) listed in the “Chassis Details” on page 3-2 section.

**Reduced Air Flow.** Installation of the equipment should be such that the amount of air flow required for safe operation of the equipment is not compromised. Refer to “Airflow / Clearance Recommendations” on page 3-9 for more information.

**Mechanical Loading.** Mounting of the equipment should be such that a hazardous condition is not achieved due to uneven loading.

**Circuit Overloading.** Consideration should be given to the connection of the equipment to the supply circuit and the effect that overloading of circuits could have on overcurrent protection and supply wiring.

**Reliable Earthing.** Reliable earthing of equipment should be maintained. Particular attention should be given to supply connections other than direct connections to the branch (e.g., use of power strips).

## Airflow / Clearance Recommendations

To ensure proper airflow, be sure that your switch is placed in a clean, well-ventilated area free of dust and debris and provide minimum recommended clearance as shown below. Restricted airflow can cause your switch to overheat, which can lead to switch failure. Refer to the following important guidelines:

Minimum Recommended Clearances - 12-port Models	
Top	N/A - (If no equipment is installed above chassis) 1 inch - (If equipment is installed above chassis).
Bottom	N/A - (If no equipment is installed below chassis) 1 inch - (If equipment is installed below chassis).
Sides	2 inches
Front / Rear	N/A
Minimum Recommended Clearances - U28 Model	
Top	1.75 inch (1RU)
Bottom	1.75 inch (1RU)
Sides	2 inches
Front / Rear	N/A

## Rack Mounting Steps (Full-width Chassis)

- 1 Attach rack mount brackets to both sides of the chassis as shown.

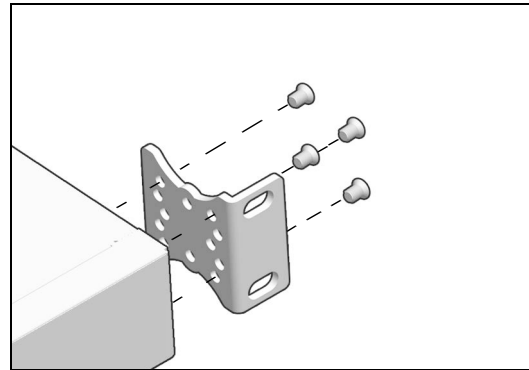
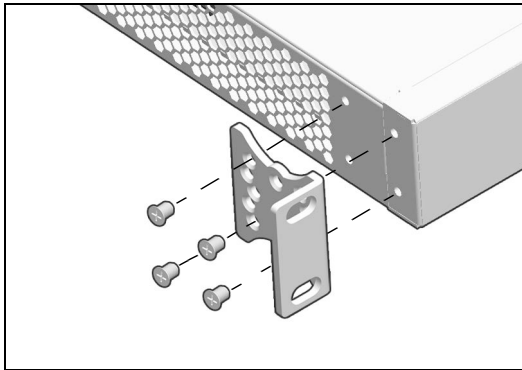

- 2 Mark the holes on the rack where the switch is to be installed.
- 3 Lift and position the switch until the rack-mount brackets are flush with the rack post, then align the holes in the brackets with the rack holes that were marked at step 1.
- 4 Once the holes are aligned, insert a rack mount screw (not provided) through the bottom hole of each bracket. Tighten both screws until they are secure.

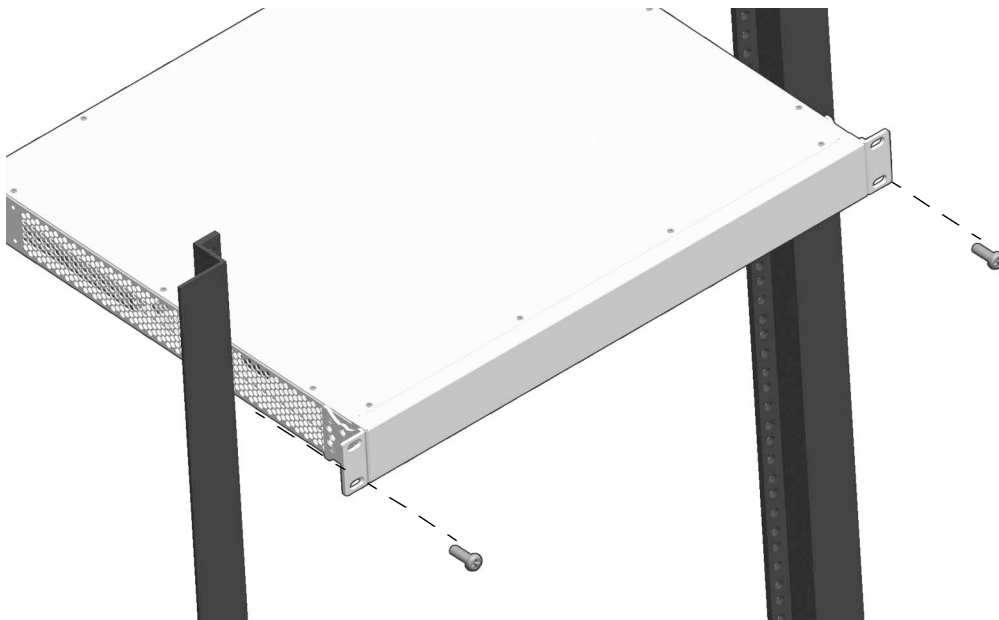

Follow the recommended clearance requirements for the model being mounted.

---

**Note.** Be sure to install the screws in the *bottom* hole of each bracket, as shown, before proceeding.

---

- 5 Once the screws at the bottom of each bracket are secure, install the remaining two rack mount screws. Be sure that all screws are securely tightened.

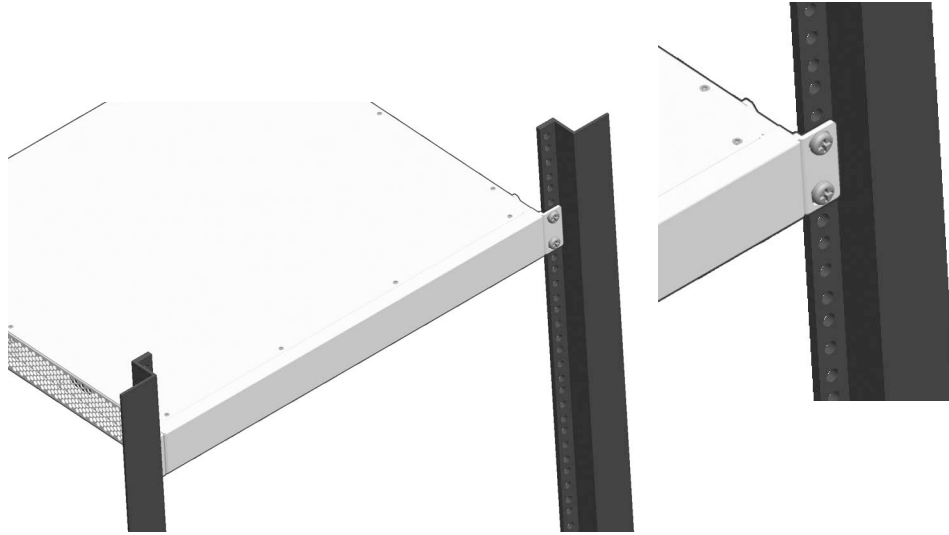

## Rack Mounting Steps (One Half-width Chassis - OS6570M-RM-19-L Kit)

A single chassis can also be mounted into a standard 19-inch rack using L-brackets, as shown in the figure below.

- 1 Attach rack mount brackets to both sides of the front of the chassis. The long and short bracket can be mounted on either side of the chassis.

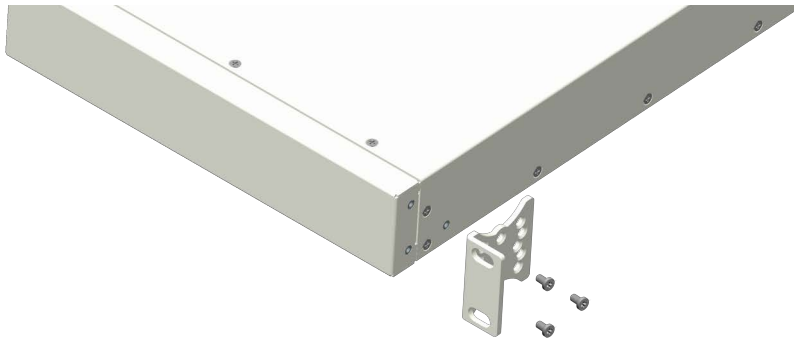

**Attach Rack Mount Brackets**

- 2 Align the holes in the flanges with the rack holes and insert rack mount screws (not provided) through the *bottom hole of each flange* and then the top of each flange. Tighten both screws until they are secure

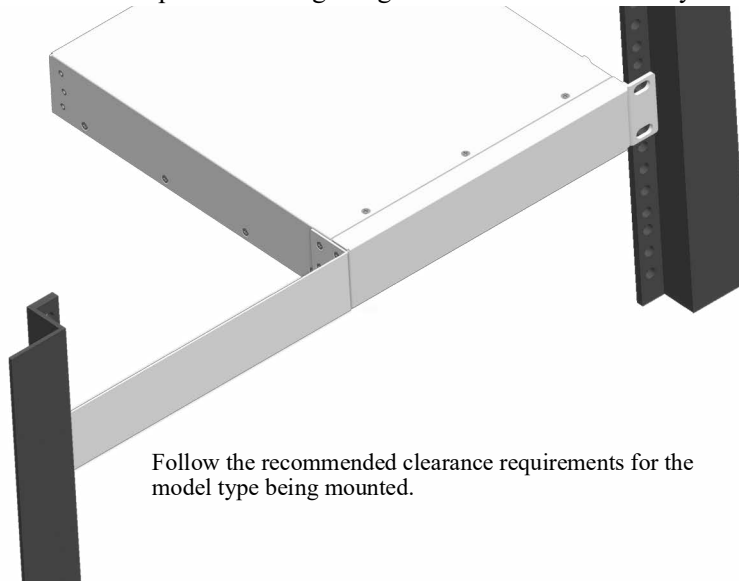

Follow the recommended clearance requirements for the model type being mounted.



## Rack Mounting Steps (Two Half-width Chassis - OS6570M-DUO-MNT Kit)

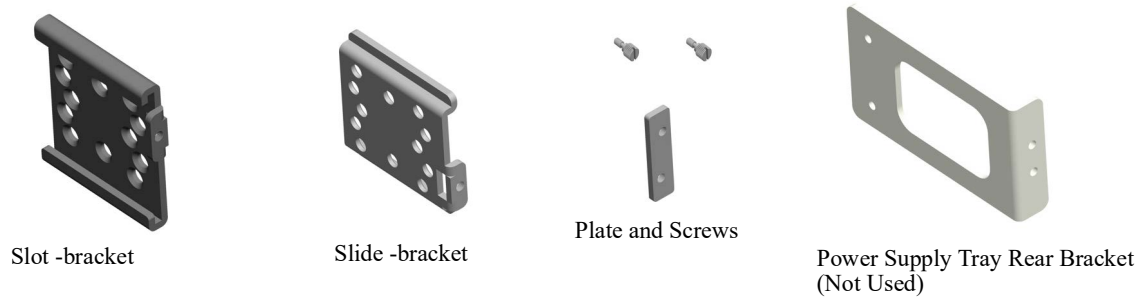

Two chassis can be assembled side-by-side for mounting into a standard 19-inch rack as show in the figure below.

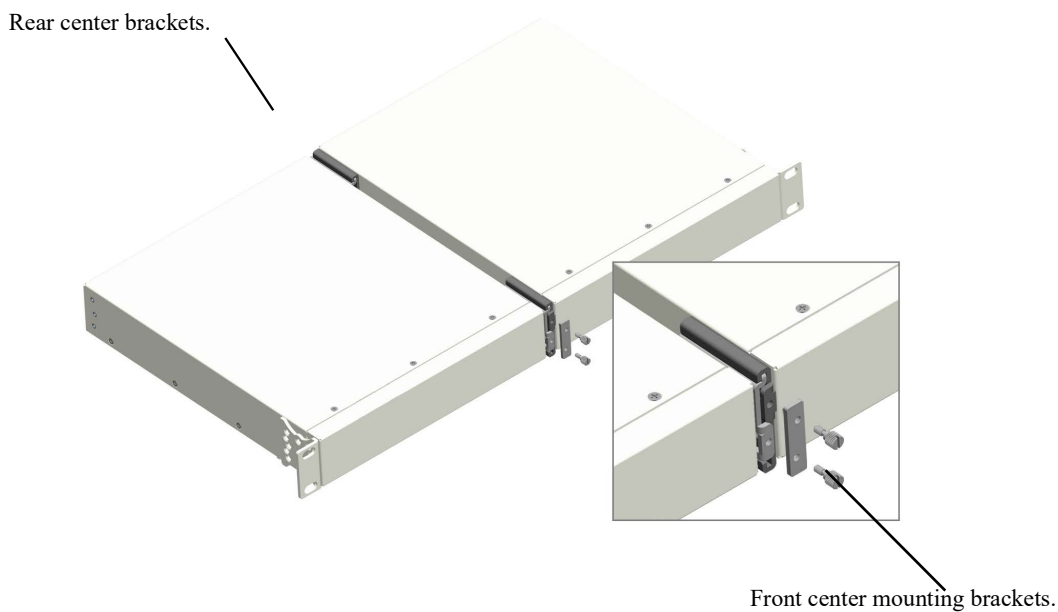

### Fully Assembled Side-by-Side Chassis Assembly

**1** Attach the slot-brackets and slide-brackets to the front and back of the chassis using the attachment screws (M3 flat head) provided for each bracket.

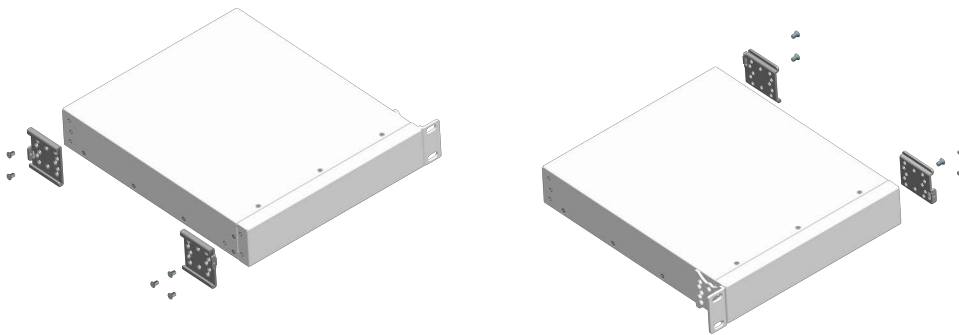

### Attach Slot/Slide-Brackets

- 2 Align the chassis and slide both front and rear center brackets together.

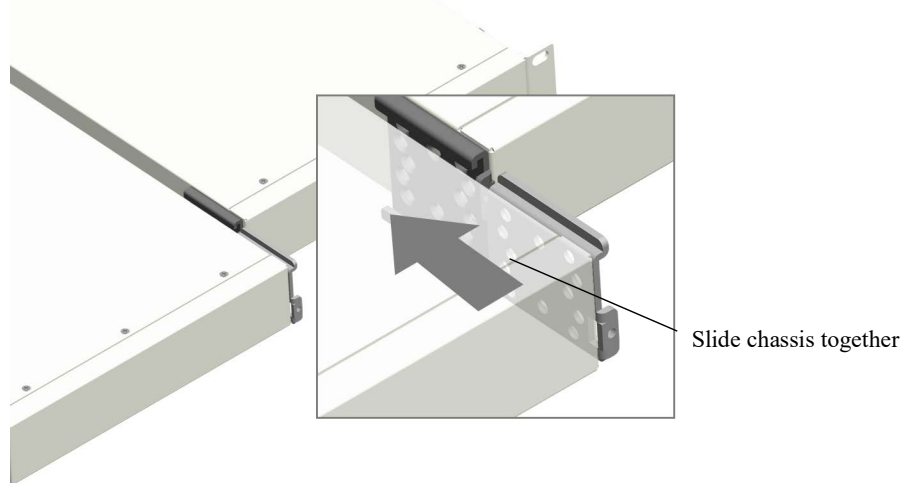

### Slide Chassis Together

- 3 Place bracket plate over front and rear brackets and secure with thumb screws.

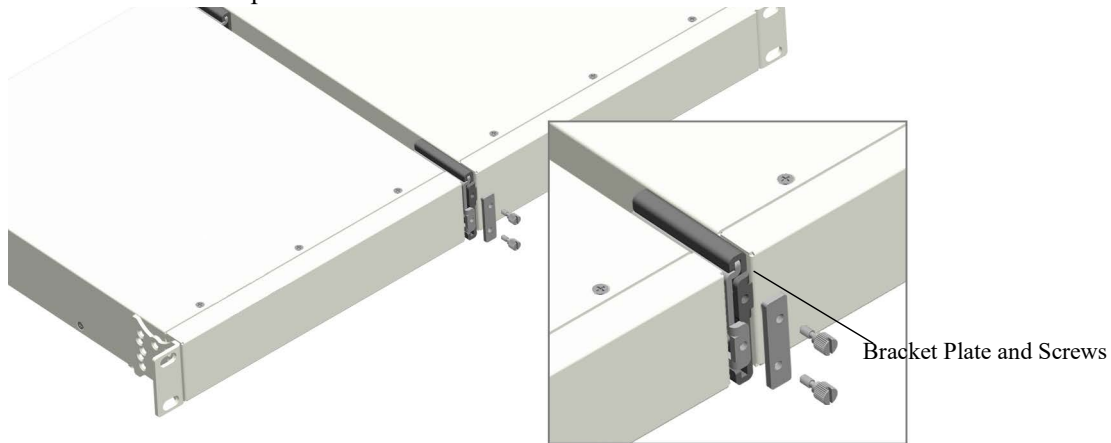

### Secure Front and Back with Bracket Plate

- 4 Attach rack mount brackets to both sides of the front of the chassis.

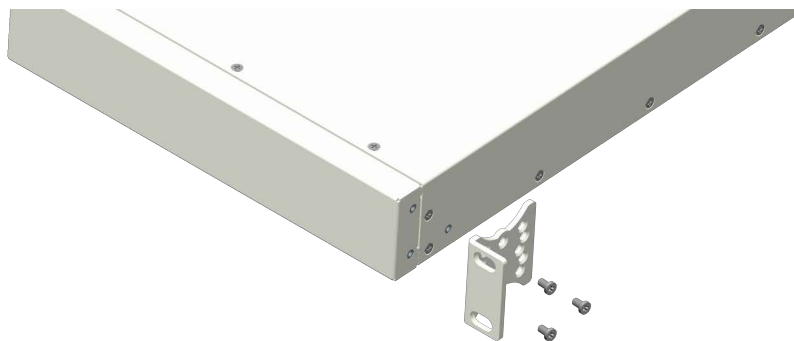

### Attach Rack Mount Brackets

- 5 Using one additional person, lift and position the assembly on the rack until the rack-mount flanges are flush with the rack post.

- 6 Align the holes in the flanges with the rack holes and insert rack mount screws (not provided) through the *bottom hole of each flange* and then the top of each flange. Tighten both screws until they are secure.

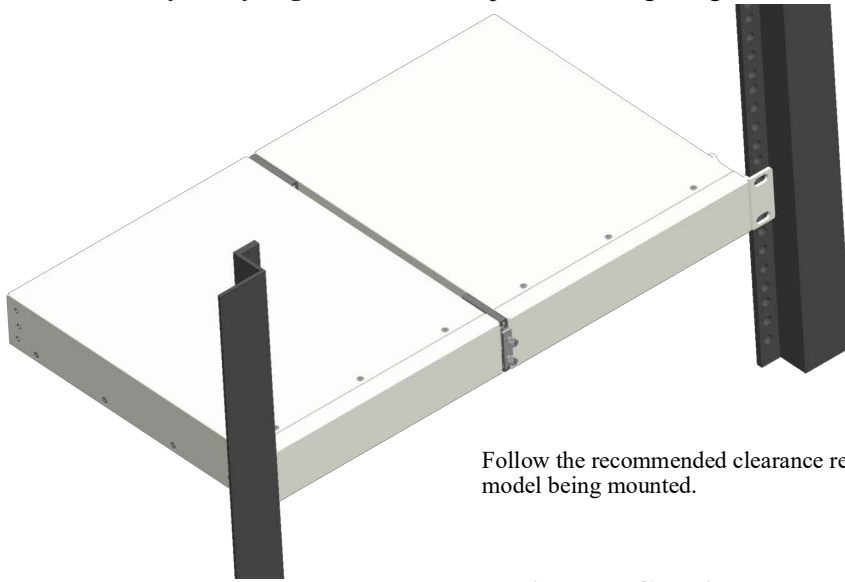

Follow the recommended clearance requirements for the model being mounted.

### Rack-mounting Two Chassis

# Power Supplies

OmniSwitch 6570M switches can use the following power supplies:

Model	Chassis Supported
Internal Power Supply (See <a href="#">page 3-16</a> )	OS6570M-12, OS6570M-12D
OS6570M-12 AC Power Supply (DA-60Z12) (See <a href="#">page 3-17</a> )	OS6570M-12
OS6570M-12D DC Power Supply (DDR-30L-12) (See <a href="#">page 3-18</a> )	OS6570M-12D
OS6570M-U28 AC Power Supply (PS-150W-AC) (See <a href="#">page 3-19</a> )	OS6570M-U28
OS6570M-U28 DC Power Supply (PS-150W-DC) (See <a href="#">page 3-20</a> )	OS6570M-U28

## Internal Power Supplies

Model	Internal AC Power Supply
Description	Internal AC 65W power supply
Models Supported	OS6570M-12
Input	100-240V, 50-60Hz
Output	12V/5.42A (65W)

Model	Internal DC Power Supply
Description	Internal DC 30W power supply
Models Supported	OS6570M-12D
Input	36-72VDC
Output	12V/5.42A (30W)

## 60W AC Power Supply

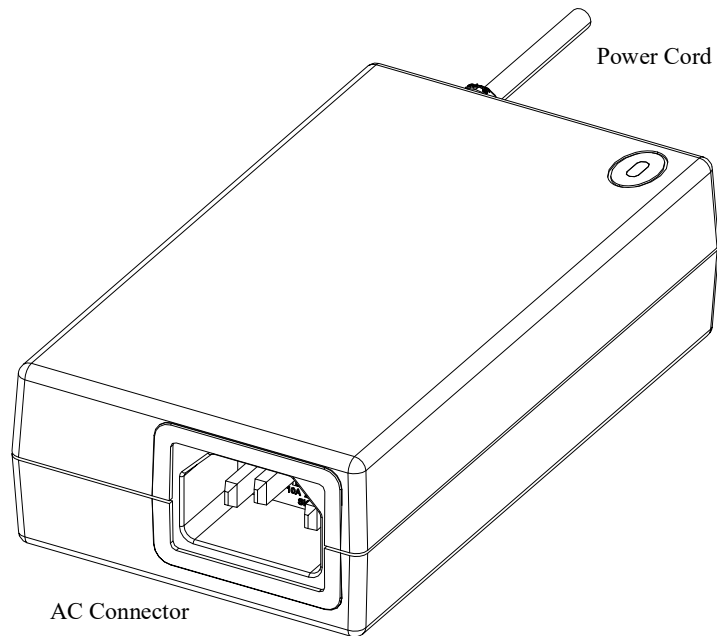

### 60W AC Power Supply

Model	OS6570-12-BP, PS-60W-AC (DA-60Z12)
Models Supported	OS6570M-12
Input	100-240VAC/50-60Hz
Output	12V/5A (60W)

## 30W DC Power Supply

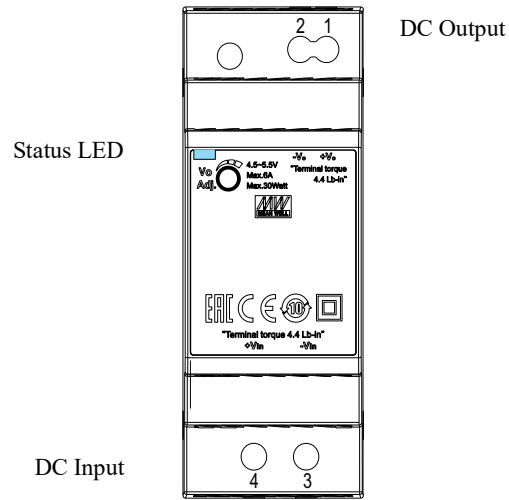

### 30W DC Power Supply

Model	OS6570-12-BP-D, PS-30W-DC (DDR-30L-12)
Models Supported	OS6570M-12D
Input	18-75VDC (Tolerances Included)
Output	12V/2.5A (30W)

### LED States

LED State	Description
Solid Green	DC power is good.
Solid Red	There is a DC power issue.

## 150W AC Power Supply

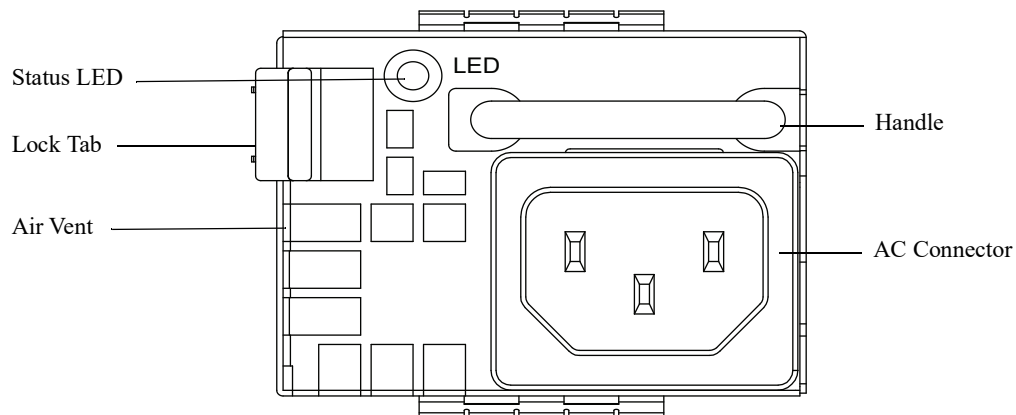

**150W AC Power Supply Front Panel**

Model	PS-150W-AC
Models Supported	OS6570M-U28
Input Voltage/Current	100-240VAC / 3-1.5A
Input Frequency	50-60Hz
Max. Output Power/Current	150 W/12.5 A
Weight	0.88 kg (1.94 lb)

### LED States

LED State	Description
<b>Solid Green</b>	The power supply is operating normally and providing power
<b>Flashing Green</b>	The power supply is on standby and can provide power to the chassis if power supply failover should occur
<b>Flashing Red</b>	No AC power is being provided to this power supply (but another power supply is installed and operating in the adjacent power supply bay)
<b>Flashing Green/Red</b>	Power supply warning
<b>Solid Red</b>	Power supply failure
<b>Off</b>	No AC power is being provided to any power supply installed in the chassis; all power supplies are effectively off

## 150W DC Power Supply

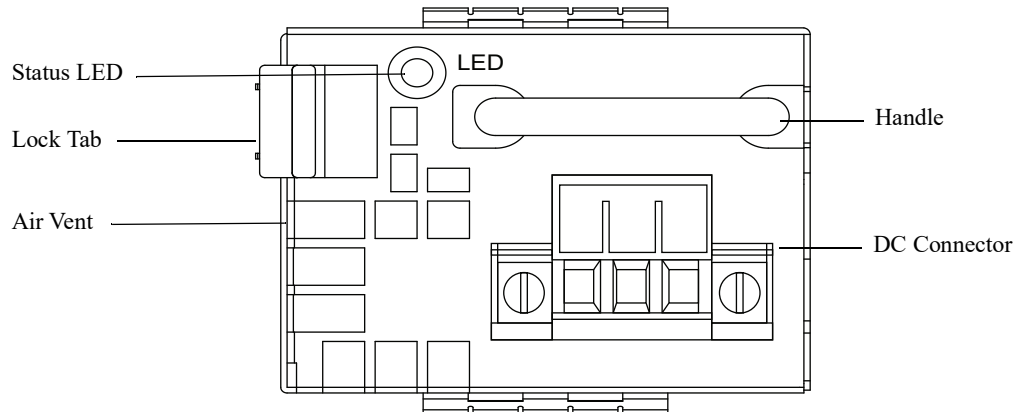

**150W DC Power Supply Front Panel**

Model	PS-150W-DC
Models Supported	OS6570M-U28
Input Voltage/Current	-36 V to-72 VDC/1.8 A to 6 A
Max. Output Power/Current	150 W/12.5 A
Weight	0.88 kg (1.94 lb)

### LED States

LED State	Description
<b>Solid Green</b>	The power supply is operating normally and providing power
<b>Flashing Green</b>	The power supply is on standby and can provide power to the chassis if power supply failover should occur
<b>Flashing Red</b>	No AC power is being provided to this power supply (but another power supply is installed and operating in the adjacent power supply bay)
<b>Flashing Green/Red</b>	Power supply warning
<b>Solid Red</b>	Power supply failure
<b>Off</b>	No power is being provided to any power supply installed in the chassis; all power supplies are effectively off



## DC Power Supply Connections

### Connecting a DC Cable Harness to the Chassis Power Supply

When plugging in the cable, insert the connector end of the cable harness into the power supply connector until it clicks firmly into place. This is an indication that the connector is secure and properly seated.

### Connecting a DC Cable Harness to the DC Power Source

#### Safety Guidelines

Before connecting the DC cable to a power source, be sure to follow these important guidelines:

- Connect to a reliably ground -48VDC Selv source.
- The branch circuit overcurrent protection must be rated 15A.
- Use 12AWG copper conductors.
- A readily accessible disconnect device that is suitably approved and rated shall be incorporated in the field wiring.
- It must be installed in a restricted access location.

#### Primary Ground Information

The product has been designed to be installed in a Common Bonding Network (CBN). The pin of the Green/Yellow ground lead in the three pin cable connector is connected to the ground connector on the DC power supply, which is identified by a Grounding symbol. The Green/Yellow lead wire at the other end of the cable must be connected to a proper earth ground point.

The rear chassis has two ground holes. To properly ground the equipment, connect a Panduit Corporation UL listed Lug, (Part number LCD8-10A-L) to the two threaded holes located at the rear, insert two 10-32, 3/8" threaded pan head screws into these ground holes, and connect them to a proper earth ground point, using protective earthing conductor wire and 8AWG copper conductors.

#### Connection Details

For DC power supply units, make the following power connections:

Connect the power supply using the supplied DC cable. The cable consists of three 12AWG wires (Green/Yellow, Black, Red).

One end of the cable has a three pin connector in a plastic housing that is inserted into a three pin input connector on the power supply. The other end of the cable is connected to a fuse panel or other source of -48VDC power.

Observe proper polarity when connecting to a fuse panel. The cable wire leads must be connected as follows:

- Green/yellow - ground
- Black - return
- Red - -48VDC

---

**Note.** The battery return conductor is an Isolated DC Return (DC-1).

---

## Installing Power Supplies

**Note.** The power supply shown in the following diagrams may differ from the actual unit. However, comparable installation and removal steps also apply to other power supply units.

- 1** Insert the power supply into a power supply bay at the rear of the chassis and slide it back until it is securely seated in the chassis backplane.

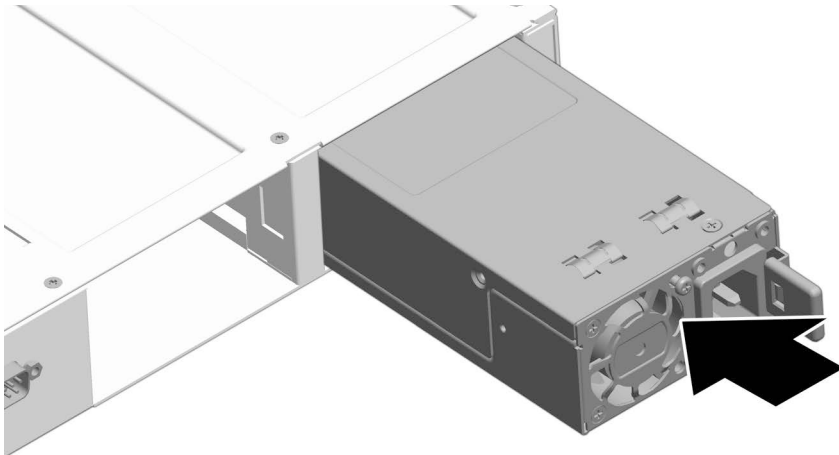

When the connector is fully seated, the lock tab will click and hold the power supply in place.

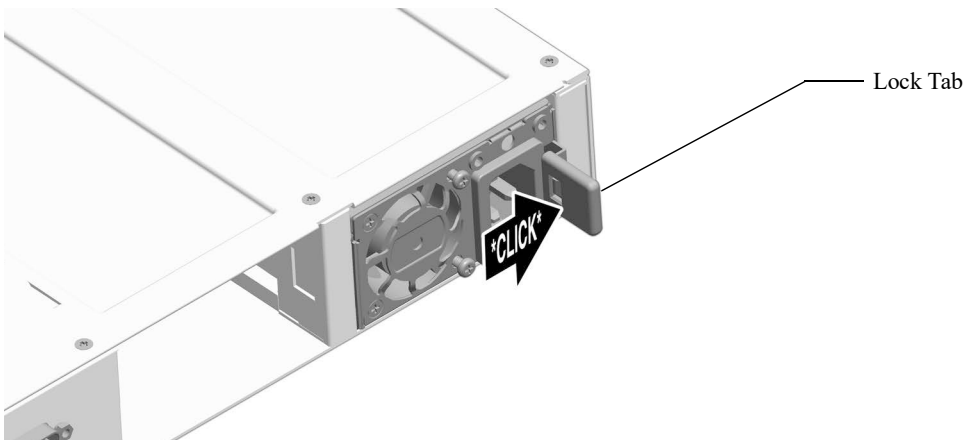

- 2** Plug the power cord (provided) into the power supply's socket.

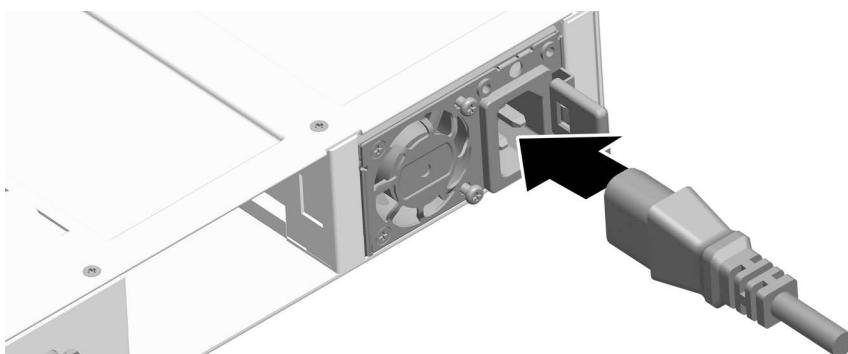

---

**Note.** The chassis *does not* provide an on/off switch. Connecting a the power supplies to a power source will boot the switch.

---

## Hot-Swapping / Removing Power Supplies

**1** When removing a power supply, first disconnect the power cord from the power source. Once the power cord is disconnected, pull the power cord out of the power supply housing.

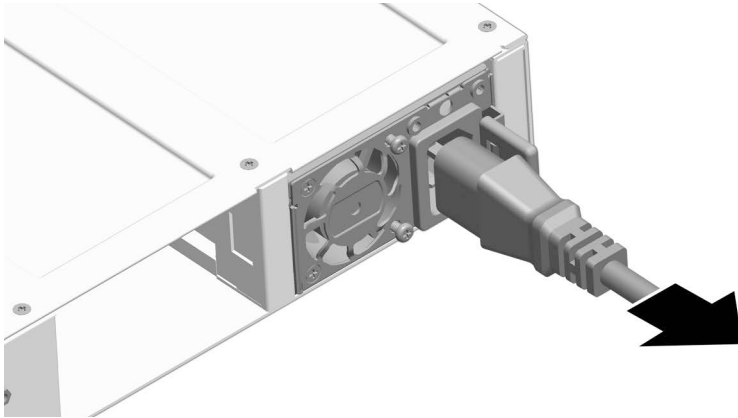

**2** Pressing the lock tab toward the center of the power supply, as shown, will free the power supply from the chassis.

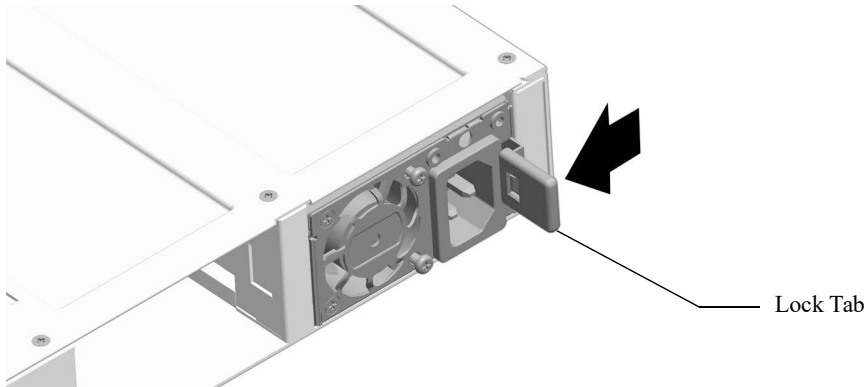

- 3 While pressing the lock tab, pull the power supply straight back and out of the chassis slot.

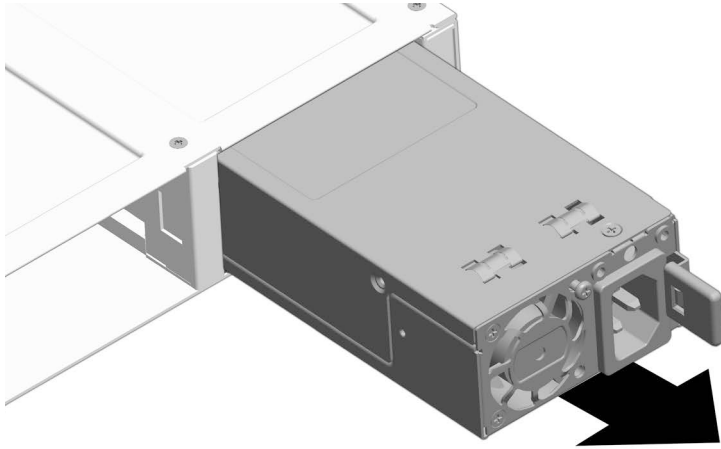

---

**Note.** If you are not replacing the power supply, be sure to install a blank cover panel over the empty power supply bay.

---

## Installing Power Supply Trays

**Note.** The same power supply tray is used for both AC and DC power supplies. Use the supplied cable ties to secure the power supply cables.

- 1 Attach the power supply tray to the chassis using the provided screws (4).
- 2 Mount the power supply to the tray and secure with the power supply bracket using the provided screws (2).
- 3 Attach power supply tray cover with screws (2).
- 4 Properly secure all cables using the supplied cable ties.

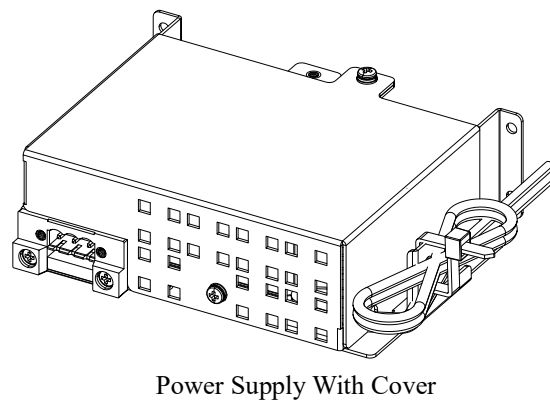
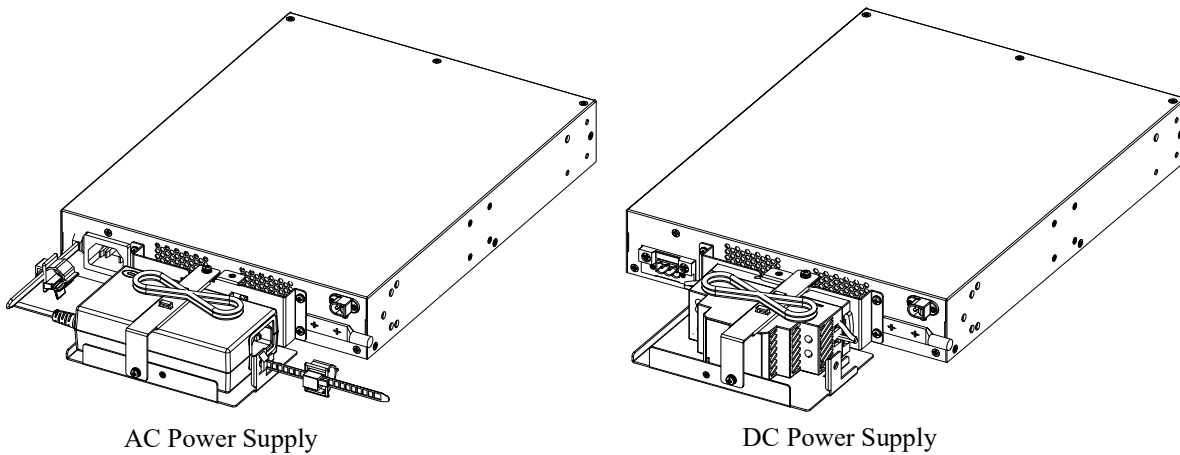

### Mounted Power Supplies and Trays

# Grounding the Chassis

The switch has a grounding lug located on the front or rear of the chassis. This lug uses 10-32 screws and is surrounded by a small paint-free area, which provides metal-to-metal contact for a ground connection.

Use this connector to supplement the ground provided by the AC power cord. To do so, install a Panduit Grounding Lug (type LCD8-10A-L) using 8AWG copper conductors to the paint-free area.

Refer to the chassis views on [page 3-2](#) for location details.

## Monitoring Chassis Components

### Viewing Chassis Slot Information

To view basic slot information, enter the show module command at the CLI prompt:

```
-> show module
```

To view more detailed information, use the show module long command:

```
-> show module long
```

### Monitoring Chassis Temperature

The operating temperature of your switch is a critical factor in its overall operability. In order to avoid a temperature-related system failure, your switch must always run at a temperature within the specified operating temperature range.

To avoid chassis over-temperature conditions, follow the important chassis airflow recommendations on [page 3-9](#).

To check the switch's current temperature status, use the [show temperature](#) command. For example:

```
-> show temperature
Chassis/Device | Current | Range      | Danger | Thresh | Status
-----+-----+-----+-----+-----+-----
1/CMMA         | 58      | 15 to 85   | 88     | 85     | UNDER THRESHOLD
```

For more information about this command, see the “Chassis Management and Monitoring Commands” chapter in the *OmniSwitch CLI Reference Guide*.

### Temperature Errors

The switch monitors the chassis temperature at all times via an onboard sensor. The threshold values are factory-set and cannot be modified. If an over-temperature condition occurs, there are two different levels of error severity:

- Warning threshold (*Thresh*) temperature has been exceeded
- Danger threshold has been exceeded

## Warning Threshold Temperature

If the temperature exceeds the switch's Warning threshold, the switch sends out a trap. Traps are also printed to the console in the form of text error messages.

When the Warning threshold has been exceeded, switch operations remain active. However, it is recommended that immediate steps be taken to address the over-temperature condition.

Addressing Warning threshold conditions may include:

- Checking for a chassis airflow obstruction
- Checking the ambient room temperature

## Danger Threshold

If the chassis temperature rises above the Danger threshold, the switch will power off until the temperature conditions have been addressed and the switch is manually booted.

Addressing the Danger threshold conditions may include:

- Checking for a chassis airflow obstruction
- Checking the ambient room temperature

# Dying Gasp

If the switch loses all power it will maintain power long enough to send a Dying Gasp message before completely shutting down. An SNMP trap, Syslog message and Link OAM PDUs will be generated.

## Scenarios

A Dying Gasp event will be generated in the following scenarios:

- Primary power supply failure (if only power supply present)
- Primary power supply failure and then backup power supply failure
- Backup power supply failure and then primary power supply failure

---

**Note.** Connect each power supply to a separate independent power source to avoid simultaneous power failures.

---

## SNMP Trap

As soon as the power failure is detected, an SNMP trap is sent to the first three configured SNMP stations. The trap includes the following information:

- Slot number
- Power supply type (primary/backup)
- Time of the failure

Use the **snmp station** command and refer to the SNMP Configuration chapter for information on configuring an SNMP station.

## Syslog Message

As soon as the power failure is detected, the following Syslog message is sent to the first three configured Syslog servers, along with the time of the failure:

```
Dying Gasp Power Failure Event Occurred
```

Use the **swlog output socket** command to add a Syslog station. Refer to the *Using Switch Logging Configuration* chapter in the *Network Configuration Guide* for information on configuring a Syslog server.

## Link OAM PDU

As soon as the power failure is detected four 802.3ah OAM Information PDUs are sent to ports for which link OAM is enabled and the LinkOAM port status is operational. The PDU will have the Dying Gasp bit set.

Use the **efm-oam** and **efm-oam port propagate-events** commands to enable the generation of an 802.3ah OAM Information PDU upon a dying gasp event:

```
-> efm-oam admin-state enable
-> efm-oam port 1/1/23-34 admin-state enable
-> efm-oam port 1/1/23-24 propagate-events dying-gasp enable
```

## Link OAM PDU Priority

It may not be possible to generate PDUs on all ports enabled for link OAM. Dying gasp packets will be sent in the following order based on port priority:

1. Uplink ports
2. All other ports



# A Regulatory Compliance and Safety Information

This appendix provides information on regulatory agency compliance and safety for the OmniSwitch.

## Declaration of Conformity: CE Mark

This equipment is in compliance with the essential requirements and other provisions of Directive 2014/30/EU (EMC), 2014/35/EU (LVD), 2011/65/EU (RoHS-Directive), 91/263/EEC (Telecom Terminal Equipment, if applicable), 2014/53/EU (R&TTE, if applicable).

**Français:** Cet équipement est conforme aux exigences essentielles et aux autres provisions de la Directive 2014/30/EU (EMC), 2014/35/EU (LVD), 2011/65/EU (RoHS-Directive), 91/263/EEC (équipements terminaux de télécommunications, le cas échéant), 2014/53/EU (R&TTE, le cas échéant).

**Deutsch:** Diese Ausrüstung erfüllt die wesentlichen Anforderungen und sonstigen Bestimmungen der Richtlinien 2014/30/EU (EMV-Richtlinie), 2014/35/EU (LVD), 2011/65/EU (RoHS-Directive), 91/263/EEC (Telekommunikationsendeinrichtungen, falls zutreffend), 2014/53/EU (Funkanlagen und Telekommunikationsendeinrichtungen, falls zutreffend).

**Español:** Este equipo cumple los requisitos esenciales y otras disposiciones de las directivas 2014/30/EU (EMC), 2014/35/EU (LVD), 2011/65/EU (RoHS-Directive), 91/263/EEC (equipos terminales de telecomunicación, si procede), 2014/53/EU (R&TTE, si procede).

## Waste Electrical and Electronic Equipment (WEEE) Statement

The product at end of life is subject to separate collection and treatment in the EU Member States, Norway and Switzerland and therefore marked with the following symbol:

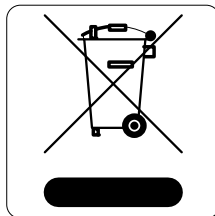

Treatment applied at end of life of the product in these countries shall comply with the applicable national laws implementing directive 2002/96/EC on waste electrical and electronic equipment (WEEE).

## China RoHS: Hazardous Substance Table

部件名称 Part Name	有毒和危险品 Toxic and Hazardous Substances or Elements					
	铅 (Pb)	水银 (Hg)	镉 (Cd)	六价铬 (Cr(VI))	多溴化苯 (PBB)	多溴化二苯醚 (PBDE)
电路模块 (Circuit Boards)	X	O	O	O	O	O
电缆及电缆组件 (Cables & Cable Accessories)	X	O	O	O	O	O
金属部件 (Metal Parts)	X	O	O	O	O	O
塑料和聚合物部件 (Plastic and Polymeric parts)	O	O	O	O	O	O
可插拔模块 (Pluggable modules)	X	O	O	O	O	O
电池 (Batteries)	O	O	O	O	O	O

本表格依据 SJ/T 11364 的规定编制

O = 表示该有害物质在该部件所有均质材料中的含量均在 GB/T 26572 规定的限量要求以下 (indicates that the content of the toxic and hazardous substance in all the Homogeneous Materials of the part is below the concentration limit requirement as described in GB/T 26572).

X = 表示该有害物质至少在该部件的某一均质材料中的含量超出 GB/T 26572 规定的限量要求 (indicates that the content of the toxic and hazardous substance in at least one Homogeneous Material of the part exceeds the concentration limit requirement as described in GB/T 26572).

## Taiwan RoHS: Hazardous Substance Table

设备名称：交換機和路由器產品						
单位	受限物质及其化学符号					
	铅 (Pb)	汞 (Hg)	镉 (Cd)	六价铬 (Cr+6)	多溴联苯 (PBB)	多溴二苯醚 (PBDE)
电路板 (Circuit Boards)	-	○	○	○	○	○
電纜及電纜配件 (Cables & Cable Accessories)	-	○	○	○	○	○
金屬部件 (Metal Parts)	-	○	○	○	○	○
塑料和聚合物部件 (Plastic and Polymeric Parts)	○	○	○	○	○	○
可插拔模塊 (Pluggable modules)	-	○	○	○	○	○
電池 (Batteries)	○	○	○	○	○	○
注 1: “○” 表示该项受限物质的含量百分比未超过百分比含量基准值。 注 2: “-” 表示该项受限物质为排除项目。						

## California Proposition 65 Warning

WARNING: This product can expose you to chemicals including Pb and Pb compounds, which is known to the State of California to cause cancer and birth defects or other reproductive harm. For more information go to [www.P65Warnings.ca.gov](http://www.P65Warnings.ca.gov).

Products are packaged using one or more of the following packaging materials:

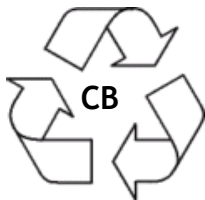

Corrugated Cardboard

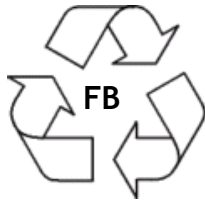

Corrugated Fiberboard



Low-Density Polyethylene

# Standards Compliance

The product bears the CE mark. In addition it is in compliance with the following other safety and EMC standards.

---

**Note.** All hardware switching modules used in an OmniSwitch switch comply with Class A standards. Modules with copper connectors meet Class A requirements using unshielded (UTP) cables.

---

## Safety Standards

- US UL 62368-1
- IEC 62368-1 Health and Safety
- CAN/CSA-C22.2 No. 62368-1-03
- NOM-019 SCFI, Mexico
- AS/NZ TS-001 and 62368:2000, Australia
- UL-AR, Argentina
- UL-GS Mark, Germany
- CU, EAC, Russia
- EN 60825-1 Laser
- EN 60825-2 Laser
- CDRH Laser
- IEC 62368-1/EN 62368-1 with all country
- deviations
- IEC 62368-1:2005, Second Edition
- CQC, China
- ANATEL, Brazil
- BSMI, Taiwan
- KCC, Korea
- UAE RoHs

**EMI/EMC Standards**

- FCC Part 15:2012, Subpart B, Class A
- ICES–003:2012 Issue 5, Class A
- ANSI C63.4-2009
- FCC CRF Title 47 Subpart B (Class A)
- VCCI (Class A)
- AS/NZS 3548 (Class A)
- CE marking for European countries (Class A)
- EN 55032 (EMI & EMC)
- EN 61000-3-2
- EN 61000-3-3
- EN 55035 (Immunity)
  - EN 61000-4-2
  - EN 61000-4-3
  - EN 61000-4-4
  - EN 61000-4-5
  - EN 61000-4-6
  - EN 61000-4-8
  - EN 61000-4-11
- IEEE 802.3: Hi-Pot Test  
(2250 V DC on all Ethernet ports)

**Environmental Standards**

- IEC 60068-2-1
- IEC 60068-2-2
- IEC 60068-2-30
- IEC 60068-2-13
- IEC 60068-2-40
- IEC 60068-2-41
- IEC 6068-2-6
- IEC 60068-2-64
- IEC 60068-2-27
- GR-63-CORE

**FCC Class A, Part 15**

This equipment has been tested and found to comply with the limits for Class A digital device pursuant to Part 15 of the FCC Rules. These limits are designed to provide reasonable protection against harmful

interference when the equipment is operated in a commercial environment. This equipment generates, uses, and can radiate radio frequency energy and, if not installed and used in accordance with the instructions in this guide, may cause interference to radio communications. Operation of this equipment in a residential area is likely to cause interference, in which case the user will be required to correct the interference at his own expense.

The user is cautioned that changes and modifications made to the equipment without approval of the manufacturer could void the user's authority to operate this equipment. It is suggested that the user use only shielded and grounded cables to ensure compliance with FCC Rules.

If this equipment does cause interference to radio or television reception, the user is encouraged to try to correct the interference by one or more of the following measures:

- Reorient the receiving antenna.
- Relocate the equipment with respect to the receiver.
- Move the equipment away from the receiver.
- Plug the equipment into a different outlet so that equipment and receiver are on different branch circuits.

If necessary, the user should consult the dealer or an experienced radio/television technician for additional suggestions.

## **Canada Class A Statement**

This equipment does not exceed Class A limits per radio noise emissions for digital apparatus, set out in the Radio Interference Regulation of the Canadian Department of Communications.

### **Avis de conformité aux normes du ministère des Communications du Canada**

Cet équipement ne dépasse pas les limites de Classe A d'émission de bruits radioélectriques pour les appareils numériques, telles que prescrites par le Règlement sur le brouillage radioélectrique établi par le ministère des Communications du Canada.

## **JATE**

This equipment meets the requirements of the Japan Approvals Institute of Telecommunications Equipment (JATE).

## **CISPR22 Class A warning**

This is a Class A product. In a domestic environment, this product may cause radio interference. Under such circumstances, the user may be requested to take appropriate countermeasures.

## Korea Emissions Statement

A 급 기기 ( 업무용 방송통신 기자재 )  
이 기기는 업무용 (A 급) 전자파적합기기로서 판  
매자 또는 사용자는 이 점을 주의하시기 바라  
며, 가정외의 지역에서 사용하는 것을 목적으  
로 합니다.

Class A Equipment (Business equipment)  
This equipment is registered for Electromagnetic  
Conformity Registration as business equipment  
(A), not home equipment. Sellers or users are  
required to take caution in this regard.

## VCCI

This is a Class A product based on the standard of the Voluntary Control Council for Interference by Information Technology Equipment (VCCI). If this equipment is used in a domestic environment, radio disturbance may arise. When such trouble occurs, the user may be required to take corrective actions.

この装置は、情報処理装置等電波障害自主規制協議会（VCCI）の基準に基づくクラスA情報技術装置です。この装置を家庭環境で使用すると電波妨害を引き起こすことがあります。この場合には使用者が適切な対策を講ずるよう要求されることがあります。

## Class A Warning for Taiwan (BSMI) and Other Chinese Markets

Warning: To avoid electromagnetic interference, this product should not be installed or used in residential environments.

警告：為避免電磁干擾，本產品不應安裝或使用於住宅環境

## Class 1M Laser Warning

CLASS 1M LASER RADIATION WHEN OPEN. DO NOT VIEW DIRECTLY WITH OPTICAL INSTRUMENTS.

## Network Cable Installation Warning

Never install exposed network cables outdoors. Install network cables per manufacturer requirements.

## Translated Safety Warnings

### Blank Panels Warning

Because they regulate airflow and help protect internal chassis components, blank cover plates should remain installed at empty module slots and power supply bays at all times.

**Français:** Les caches blancs remplissent trois fonctions importantes: ils évitent tout risque de choc électrique à l'intérieur du châssis, ils font barrage aux interférences électromagnétiques susceptibles d'altérer le fonctionnement des autres équipements et ils dirigent le flux d'air de refroidissement dans le

châssis. Il est vivement recommandé de vérifier que tous les caches, modules d'alimentation et plaques de protection sont en place avant d'utiliser le système.

**Deutsch:** Die leeren Modulblenden schützen interne Komponenten und leiten den Luftstrom. Deshalb müssen in allen unbelegten Slots die Modulblenden immer installiert bleiben.

**Español:** Las tapaderas blancas regulan la circulación de aire y ayudan a proteger componentes internos del chasis y siempre deben estar instaladas en las ranuras vacías del chasis y fuentes de alimentación.

## Electrical Storm Warning

To avoid a shock hazard, do not connect or disconnect any cables or perform installation, maintenance, or reconfiguration of this product during an electrical storm.

**Français:** Ne pas travailler sur le système ni brancher ou débrancher les câbles pendant un orage.

**Deutsch:** Um elektrische Schläge zu vermeiden dürfen während eines Gewitters an diesem Gerät keine Kabel angeschlossen oder gelöst werden, sowie keinerlei Installationen, Wartungen oder Konfigurationen vorgenommen werden.

**Español:** Para evitar peligro de descargas, no conecte o desconecte ningún cable, ni realice ninguna instalación, mantenimiento o reconfiguración de este producto durante una tormenta eléctrica.

## Installation Warning

Only personnel knowledgeable in basic electrical and mechanical procedures should install or maintain this equipment.

**Français:** Toute installation ou remplacement de l'appareil doit être réalisée par du personnel qualifié et compétent.

**Deutsch:** Dieses Gerät soll nur von Personal installiert oder gewartet werden, welches in elektrischen und mechanischen Grundlagen ausgebildet ist.

**Español:** Estos equipos deben ser instalados y atendidos exclusivamente por personal adecuadamente formado y capacitado en técnicas eléctricas y mecánicas.

## Invisible Laser Radiation Warning

Lasers emit invisible radiation from the aperture opening when no fiber-optic cable is connected. When removing cables do not stare into the open apertures. In addition, install protective aperture covers to fiber ports with no cable connected.

**Français:** Des radiations invisibles à l'œil nu pouvant traverser l'ouverture du port lorsque aucun câble en fibre optique n'y est connecté, il est recommandé de ne pas regarder fixement l'intérieur de ces ouvertures. Installez les caches connecteurs prévus à cet effet.

**Deutsch:** Die Laser strahlen an der Blendenöffnung unsichtbares Licht ab, wenn keine Glasfaserkabel angeschlossen sind. Blicken Sie nicht in die Öffnungen und installieren Sie unverzüglich die Abdeckungen über den Glasfaseranschlüssen.

**Español:** Debido a que la apertura del puerto puede emitir radiación invisible cuando no hay un cable de fibra conectado, procurar no mirar directamente a las aperturas para no exponerse a la radiación.



## Operating Voltage Warning

To reduce the risk of electrical shock, keep your hands and fingers out of power supply bays and do not touch the backplane while the switch is operating.

**Français:** Pour réduire tout risque électrique, gardez vos mains et doigts hors des alimentations et ne touchez pas au fond de panier pendant que le commutateur fonctionne.

**Deutsch:** Um die Gefahr des elektrischen Schlages zu verringern, greifen sie bitte nicht in die Spannungsversorgung und berühren sie nicht die Rückwandplatine während das Gerät arbeitet.

**Español:** Para reducir el riesgo de descargas eléctricas, no meta sus manos y dedos dentro del chasis de la fuente de alimentación y no toque componentes internos mientras que el interruptor está conectado.

## Power Disconnection Warning

Your switch is equipped with multiple power supplies. To reduce the risk of electrical shock, be sure to disconnect all power connections before servicing or moving the unit.

**Français:** Il se peut que cette unité soit équipée de plusieurs raccordements d'alimentation. Pour supprimer tout courant électrique de l'unité, tous les cordons d'alimentation doivent être débranchés.

**Deutsch:** Ihr Gerät ist mit mehreren Netzteilen ausgerüstet. Um die Gefahr des elektrischen Schlages zu verringern, stellen sie sicher, daß alle Netzverbindungen getrennt sind bevor das Gerät gewartet oder bewegt wird.

**Español:** Antes de empezar a trabajar con un sistema, asegurese que el interruptor está cerrado y el cable eléctrico desconectado.

## Proper Earthing Requirement Warning

To avoid shock hazard:

- The power cord must be connected to a properly wired and earth receptacle.
- Any equipment to which this product will attached must also be connected to properly wired receptacles.

### Français:

Pour éviter tout risque de choc électrique:

- Ne jamais rendre inopérant le conducteur de masse ni utiliser l'équipement sans un conducteur de masse adéquatement installé.
- En cas de doute sur la mise à la masse appropriée disponible, s'adresser à l'organisme responsable de la sécurité électrique ou à un électricien.

### Deutsch:

Aus Sicherheitsgründen:

- darf das Netzkabel nur an eine Schutzkontaktsteckdose angeschlossen werden.
- dürfen für den Anschluß anderer Geräte, welche mit diesem Gerät verbunden sind, auch nur Schutzkontaktsteckdosen verwendet werden.

### Español:

Para evitar peligro de descargas:

- Para evitar peligro de descargas asegurese de que el cable de alimentación está conectado a una toma de alimentación adecuadamente cableada y con toma de tierra.

- Cualquier otro equipo a cual se conecte este producto también debe estar conectado a tomas de alimentación adecuadamente cableadas.

## DC Power Supply Connection Warning

For EMC/EMI, each DC/DC power supply requires that the ground wire is connected from each DC/DC power supply to Earth Ground.

**Français:** Pour EMC/EMI, pour chaque alimentation DC/DC, il est impératif que le fil de terre soit branché à la prise de terre.

**Deutsch:** Zur Erfüllung der EMV-/EMI-Anforderungen muss das Erdungskabel jedes DC/DC-Netzteils an eine Erde angeschlossen werden.

**Español:** Para EMC/EMI, cada fuente de alimentación de CC/CC requiere que el cable de tierra esté conectado desde cada fuente de alimentación de CC/CC a la conexión a tierra.

## Read Important Safety Information Warning

The *Getting Started Guide* that accompanied this equipment contains important safety information about which you should be aware when working with hardware components in this system. You should read this guide before installing, using, or servicing this equipment.

**Français:** Avant de brancher le système sur la source d'alimentation, consultez les directives d'installation disponibles dans le "Getting Started Guide".

**Deutsch:** Der Getting Started Guide, welcher dieser Anlage beiliegt, enthält wichtige Sicherheitsinformationen, über die sie sich beim Arbeiten mit den Hardwareeinheiten bewußt sein sollten. Sie sollten diese Hinweise lesen, bevor sie installieren, reparieren oder die Anlage verwenden.

**Español:** La 'Getting Started Guide' que acompañó este equipo contiene información importante de seguridad sobre la cual usted debe estar enterado al trabajar con los componentes de dotación física en este sistema. Usted debe leer esta guía antes de instalar, usar o mantener este equipo.

## Restricted Access Location Warning

This equipment should be installed in a location that restricts access. A restricted access location is one where access is secure and limited to service personnel who have a special key, or other means of security.

**Français:** Le matériel doit être installé dans un local avec accès limité ou seules les personnes habilitées peuvent entrer.

**Deutsch:** Die Anlage sollte an einem Standort mit beschränktem Zutritt installiert sein. Ein Standort mit beschränktem Zutritt stellt sicher, daß dort nur Servicepersonal mit Hilfe eines Schlüssels oder eines anderen Sicherheitssystems Zugang hat.

**Español:** Este equipo se debe instalar en un sitio con acceso restringido. Un sitio con el acceso restringido es uno seguro y con acceso limitado al personal de servicio que tiene una clave especial u otros medios de seguridad.

## Wrist Strap Warning

Because electrostatic discharge (ESD) can damage switch components, you must follow proper procedures to eliminate ESD from your person and the surrounding area before handling switch components.

**Français:** Parce que les décharges électrostatiques (ESD) peuvent endommager les composants de commutation, vous devez suivre les procédures appropriées pour éliminer ESD de votre personne et la région environnante avant de manipuler les composants de commutation.

**Deutsch:** Da elektrostatische Entladung (ESD) Komponenten beschädigen können, müssen geeignete Verfahren getroffen werden, diese elektrostatische Entladung bedingt durch Ihre Person oder der Umgebung zu beseitigen.

**Español:** Debido a las descargas electrostáticas (ESD) puede dañar los componentes del interruptor, debe seguir los procedimientos adecuados para eliminar la ESD de su persona y sus alrededores antes de manipular los componentes del interruptor.

## Instrucciones de seguridad en español

### Advertencia sobre el levantamiento del chasis

Se requieren dos personas para levantar el chasis. Debido a su peso, la elevación del chasis sin ayuda puede causar daños corporales. También es seguro doblar sus rodillas y guardar su espalda derecho al ayudar a levantar el chasis.

### Advertencia de las tapaderas en blanco

Porque regulan la circulación de aire y ayudan a proteger componentes internos del chasis, las tapaderas en blanco deben seguir instaladas en las ranuras vacías del módulo y la fuente de alimentación siempre.

### Advertencia en caso de tormenta eléctrica

Para evitar peligro de descargas, no conecte o desconecte ningún cable, ni realice ninguna instalación, mantenimiento o reconfiguración de este producto durante una tormenta eléctrica.

### Advertencia de instalación

Solamente el personal bien informado en procedimientos eléctricos y mecánicos básicos debe instalar o mantener este equipo.

### Advertencia de radiación láser invisible

Los lasers emiten radiación invisible de la apertura abierta cuando no se conecta ningún cable de fibra óptica. Al quitar los cables no mire fijamente en las aberturas abiertas. Además, instale las cubiertas protectoras de la apertura a las salidas de la fibra sin el cable conectado.

### Advertencia de la batería de litio

Hay un peligro de la explosión si la batería del litio en su chasis se substituye incorrectamente. Substituya la batería solamente por el mismo o el equivalente de tipo de batería recomendado por el fabricante. Deseche las baterías usadas según las instrucciones del fabricante. Las instrucciones del fabricante son como sigue: Devuelva el módulo con la batería del litio a Alcatel-Lucent. La batería del litio será substituida en la fábrica de Alcatel-Lucent.

### Advertencia sobre la tensión de operación

Para reducir el riesgo del choque eléctrico, matenga sus manos y dedos fuera de la fuente de alimentación y no toque la placa madre mientras que el interruptor está funcionando.

## **Advertencia sobre la desconexión de la fuente**

Su interruptor esta equipado por fuentes de alimentación múltiples. Para reducir el riesgo de choque eléctrico, asegúrese desconectar todas las conexiones de alimentación antes de mantener o de mover la unidad.

## **Advertencia sobre una apropiada conexión a tierra**

Para evitar peligro de descargas:

- El cable de alimentación debe estar conectado a una toma de alimentación adecuadamente cableada y con toma de tierra.

Cualquier equipo al cual se conecte este producto debe estar también conectado a tomas de alimentación adecuadamente cableadas.

## **Leer “información importante de seguridad”**

La *Guía de “Comenzando a Usar”* que acompaña este equipo contiene información importante de seguridad sobre la cual usted debe saber al trabajar con los componentes de dotación física en este sistema. Usted debe leer esta guía antes de instalar, de usar, o de mantener este equipo.

## **Advertencia de acceso restringido**

Este equipo se debe instalar en una ubicación que restrinja el acceso. Una ubicación con acceso restringido es una donde está seguro y limitado el acceso al personal de servicio que tiene un clave especial, u otros medios de la seguridad.

## **Advertencia de pulsera antiestática**

Debido a que la descarga electrostática (ESD) puede dañar componentes del interruptor, usted debe conectarse a tierra correctamente antes de continuar con la instalación del equipo. Para este propósito, Alcatel-Lucent proporciona una pulsera antiestática y un terminal que pone a tierra situados cerca de la parte superior derecha del chasis. Para que la pulsera antiestática sea eficaz en la eliminación de ESD, las fuentes de alimentación se deben instalar en el chasis y enchufar en las salidas de CA con descarga a tierra.

## **Clase de seguridad**

Cumple con 21CFR 1040.10 y 1040.11 ó sus equivalentes.

## **Advertencia de fuentes de poder**

Las unidades OmniSwitch pueden estar equipadas con tres cordones para fuente de poder. Para reducir el riesgo de un choque eléctrico, desconecte todos los cordones de fuente de poder antes de dar servicio a la unidad.